

# BP500 Transforming the control of hot tubs

## Incomparable system reliability

The BP500 is the first of a new series based on Balboa's most popular models, utilizing advanced technology and higher flame retardant and impact resistant materials. WiFi ready with press and hold buttons for ease of use, meet the newly designed BP500.

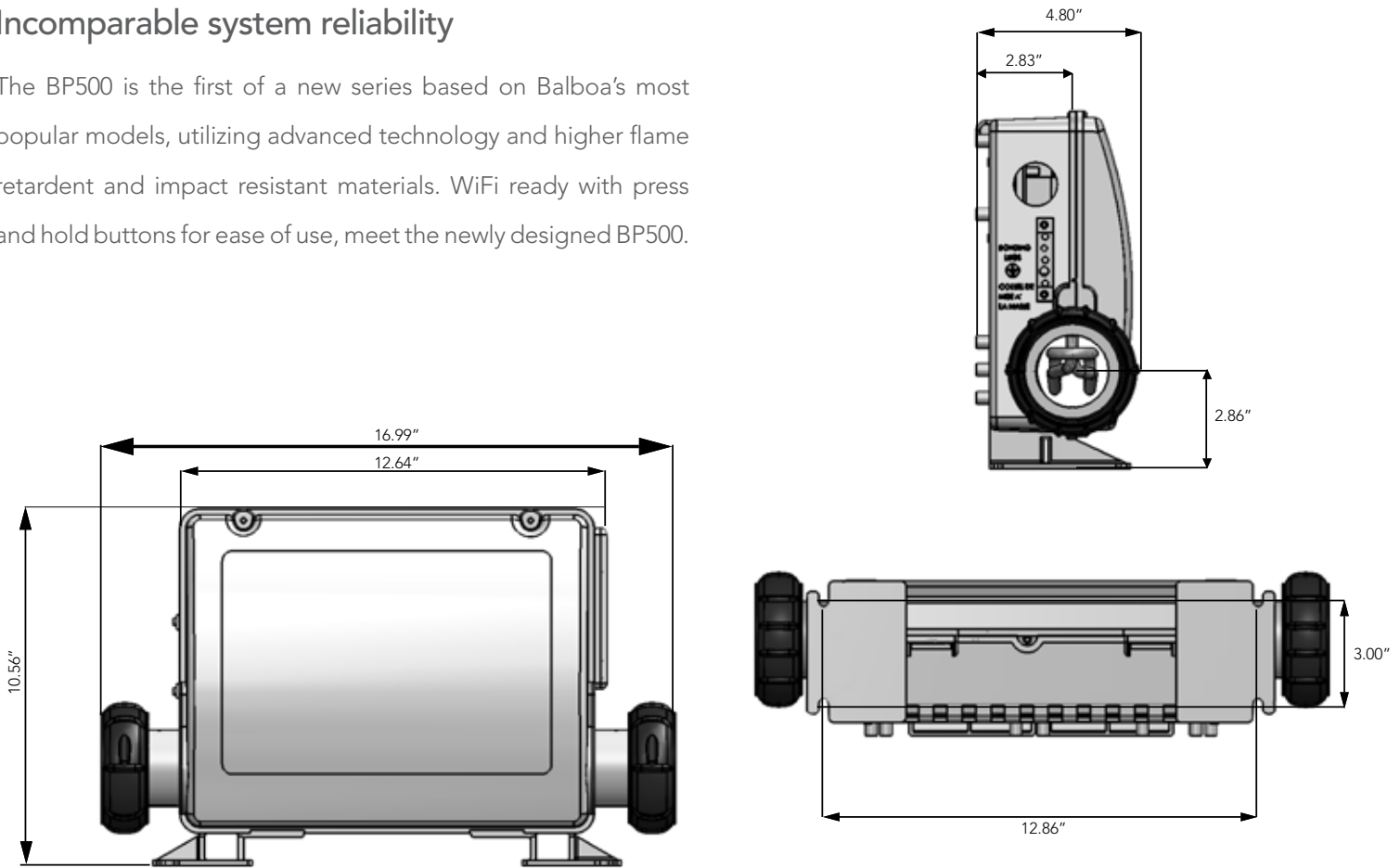

### System Specifications

Recommended Ozone Support	Balboa ozone (UL certified)
Voltage Supply	240V or 120V
Sensors	M7 patented temperature probes
Certifications	UL recognized
Spa Light Control	1AMP Max

System Material Number	Descriptions	Pump 1	Pump 2 or Blower	Heater
56278	System Balboa BP500 (Domestic)	2 spd or 1 spd with Circ	1 spd	4.0 kW 800 Incoloy Element
56279	System Balboa BP500 (Domestic)	2 spd or 1 spd with Circ	1 spd	4.0 kW 825 Incoloy Element
56280	System Balboa BP500 (Domestic)	2 spd or 1 spd with Circ	1 spd	4.0 kW Titanium Element

### Compatible Plumbing Kits (Coupling nuts and seals included)

55911	2" Tailpieces (2-Speed Pump 1)
-------	--------------------------------