

NESPA
TILED SPAS

Production Booklet

for

6th AVE PENTHOUSE SMALL POOL

2800 Richter Ave. Suite C, Oroville, CA 95965 • **voice:** (530)534-9910
fax: (530)534-9915 • **email:** sales@tiledspas.com • **website:** www.tiledspas.com

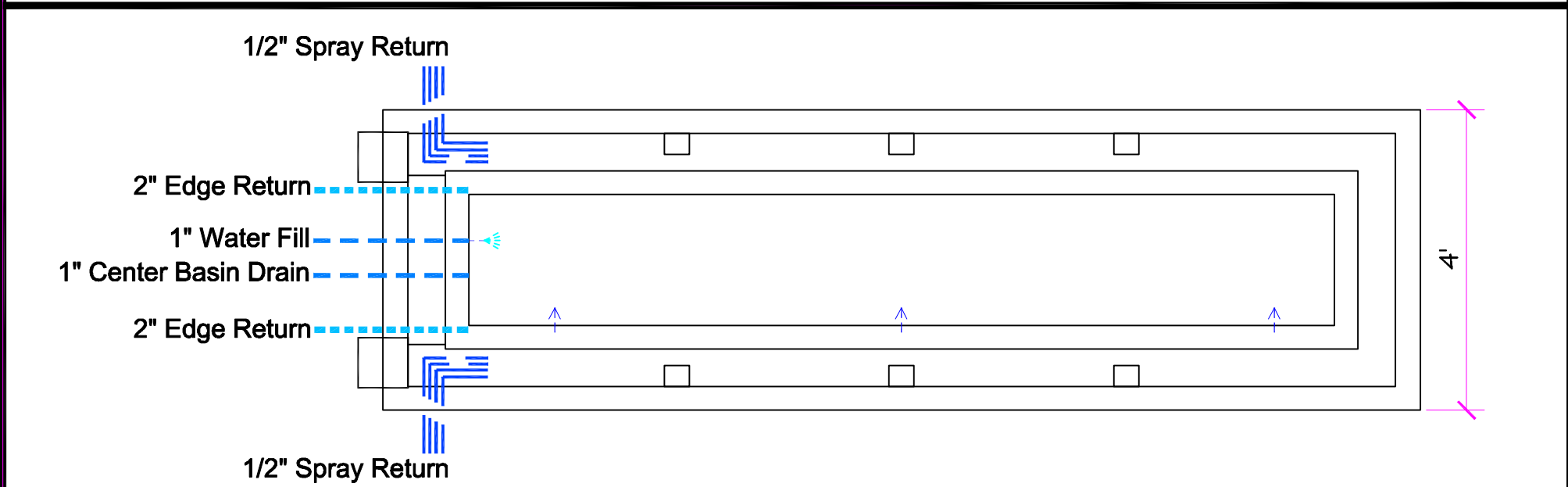
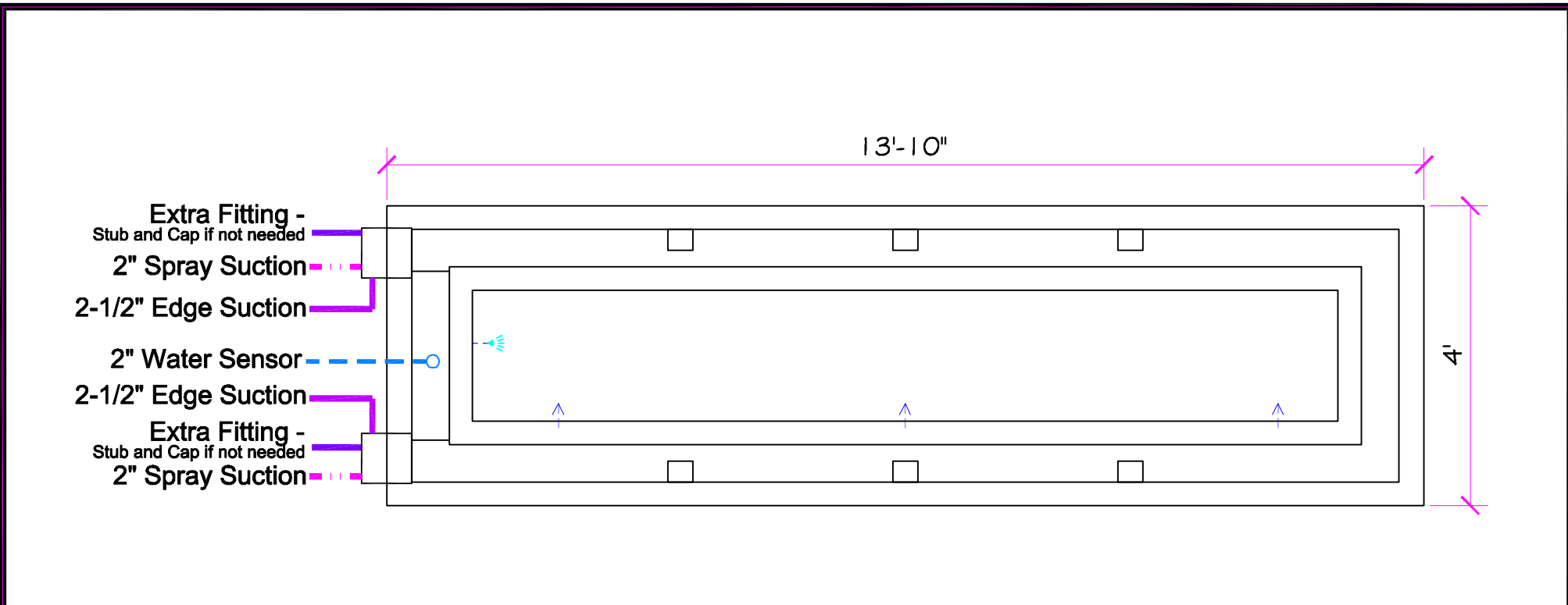

ALL DIMENSIONS SUBJECT TO 1/4" TOLERANCES

These drawings, concepts, and details contained herein are the original proprietary designs of NESPA ENTERPRISES, developed over many years of experience in the industry and as such are protected by the copyright laws of the United States Government. Reproduction of any of the above without written permission to do so by NESPA ENTERPRISES, is illegal.

NESPA ENTERPRISES INC.
 2800 Richter Ave. Ste. C Oroville, CA 95966
 Office: (530) 534-9910 Fax: (530) 534-9915
 E-Mail: sales@tiledspas.com Web Site: www.tiledspas.com



If printing as a PDF:
 Page Scaling:

DWG NAME: 6TH AVE PENTHOUSE_SMALL

SCALE: 1/2" = 1'
 0 1/4 1/2 3/4 1"

DATE: 10/5/2009

Oct 05, 2009 - 1:01pm

DWG TYPE: SD

SHEET: PAGE 1 OF 9

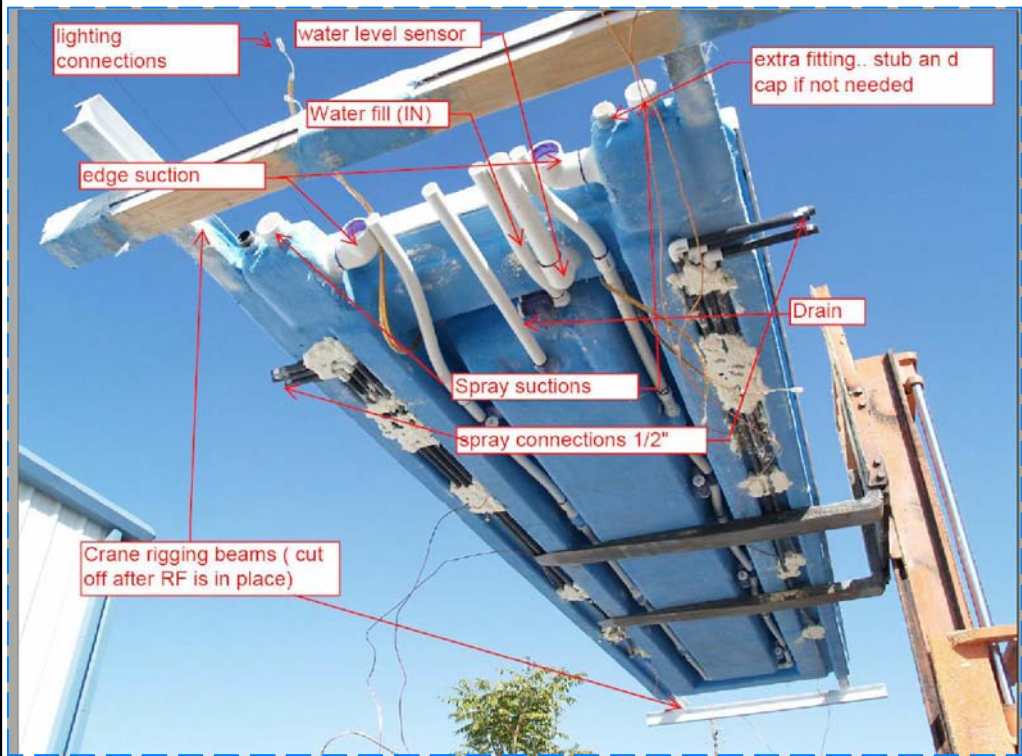

ALL DIMENSIONS SUBJECT TO 1/4" TOLERANCES

These drawings, concepts, and details contained herein are the original proprietary designs of NESPA ENTERPRISES, developed over many years of experience in the industry and as such are protected by the copyright laws of the United States Government. Reproduction of any of the above without written permission to do so by NESPA ENTERPRISES, is illegal.

NESPA ENTERPRISES INC.

2800 Richter Ave. Ste. C Oroville, CA 95966

Office: (530) 534-9910

Fax: (530) 534-9915

E-Mail: sales@tiledspas.com

Web Site: www.tiledspas.com



If printing as a PDF:

Page Scaling:

SCALE

N/A

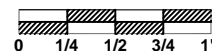

DWG TYPE

Plumbing ID

DWG NAME

6TH AVE PENTHOUSE_SMALL

DATE

10/5/2009

SHEET

PAGE 2 OF 9

Oct 05, 2009 - 1:01pm

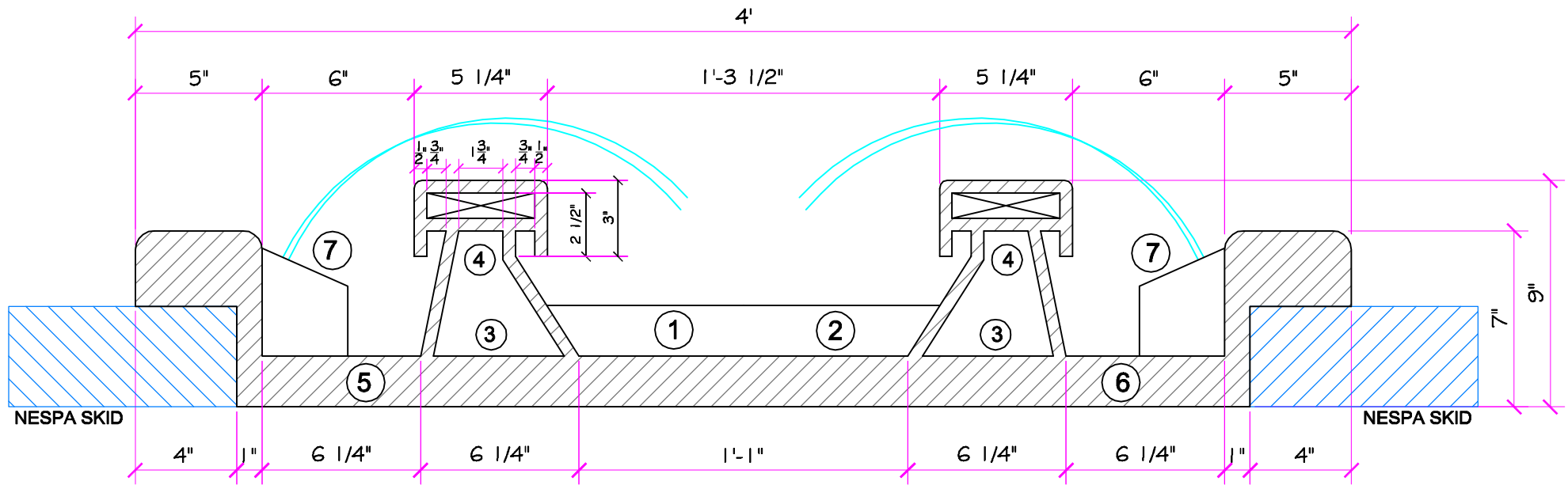

- 1. WATER FILL
- 2. BASIN DRAIN
- 3. PUMP RETURN
- 4. LIGHTS
- 5. SPRAY JETS - SUCTION
- 6. EDGE - SUCTION
- 7. SPRAY NOZZLES

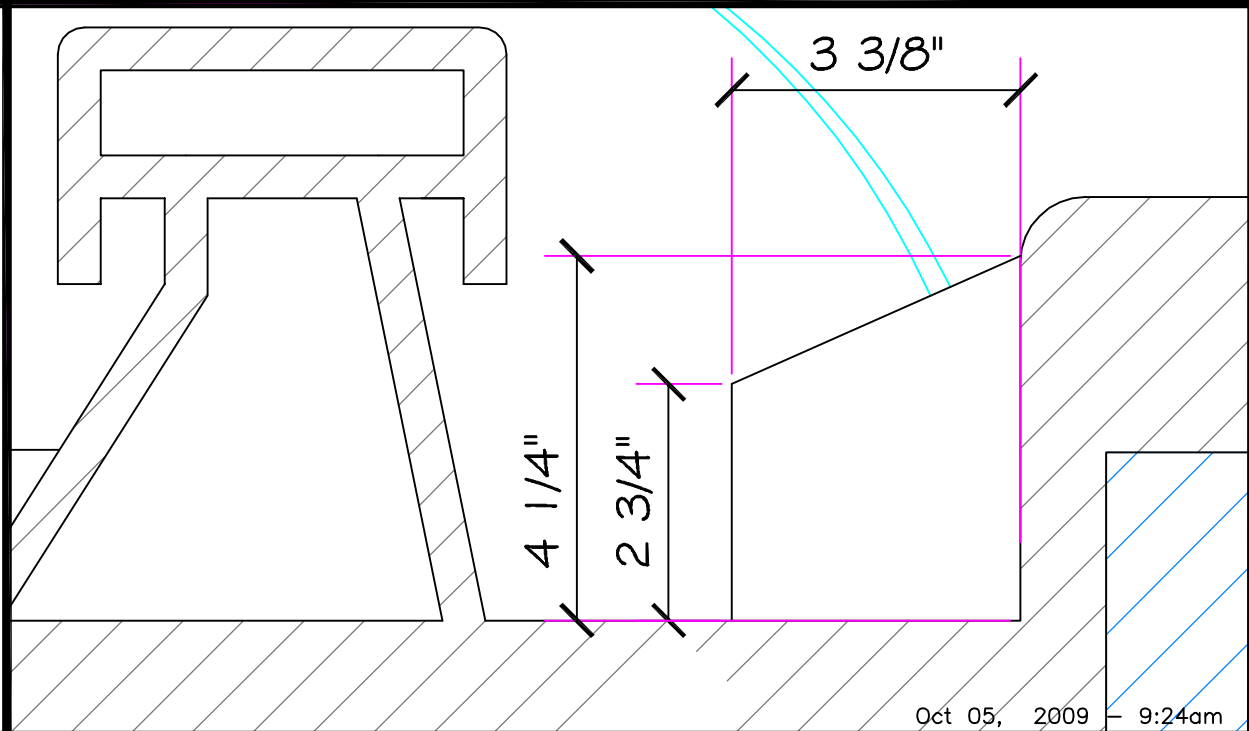

ALL DIMENSIONS SUBJECT TO 1/4" TOLERANCES

These drawings, concepts, and details contained herein are the original proprietary designs of NESPA ENTERPRISES, developed over many years of experience in the industry and as such are protected by the copyright laws of the United States Government. Reproduction of any of the above without written permission to do so by NESPA ENTERPRISES, is illegal.

NESPA ENTERPRISES INC.
 2800 Richter Ave. Ste. C Oroville, CA 95966
 Office: (530) 534-9910 Fax: (530) 534-9915
 E-Mail: sales@tiledspas.com Web Site: www.tiledspas.com



If printing as a PDF:
 Page Scaling:
 DWG NAME: 6TH AVE PENTHOUSE_SMALL

SCALE
 2" = 1'

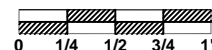

DATE: 7/31/2009

Oct 05, 2009 9:24am

DWG TYPE: Section
 SHEET: PAGE 3 OF 9

NOTES: Nespa to supply and install LED light strip
 Lights are bright, dimmable and submersible

Electrician to supply all Switching, Transformers
 and Load Wiring to Vessels

| | LED Length | Watts |
|----|------------|-------|
| 1A | 16' | 23 |
| 2A | 16' | 23 |
| 3A | 16' | 23 |
| 4A | 16' | 23 |

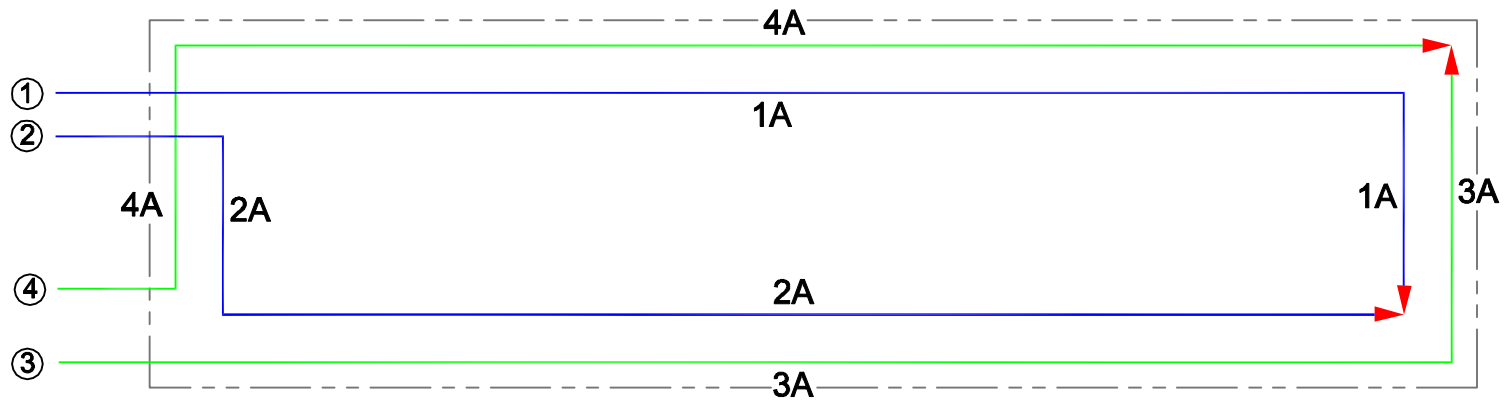

ALL DIMENSIONS SUBJECT TO 1/4" TOLERANCES

Oct 05, 2009 -- 9:24am

These drawings, concepts, and details contained herein are the original proprietary designs of NESPA ENTERPRISES, developed over many years of experience in the industry and as such are protected by the copyright laws of the United States Government. Reproduction of any of the above without written permission to do so by NESPA ENTERPRISES, is illegal.

NESPA ENTERPRISES INC.
 2800 Richter Ave. Ste. C Oroville, CA 95966
 Office: (530) 534-9910 Fax: (530) 534-9915
 E-Mail: sales@tiledspas.com Web Site: www.tiledspas.com



If printing as a PDF:

Page Scaling: None

SCALE

1/2" = 1'

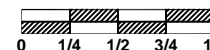

DWG TYPE

Lighting

DWG NAME

6TH AVE PENTHOUSE_SMALL

DATE

7/31/2009

SHEET

PAGE 4 OF 9

Spray Nozzle Regulator
and Valve Control
Manifold

RF POOL (Small)
Spray Pump

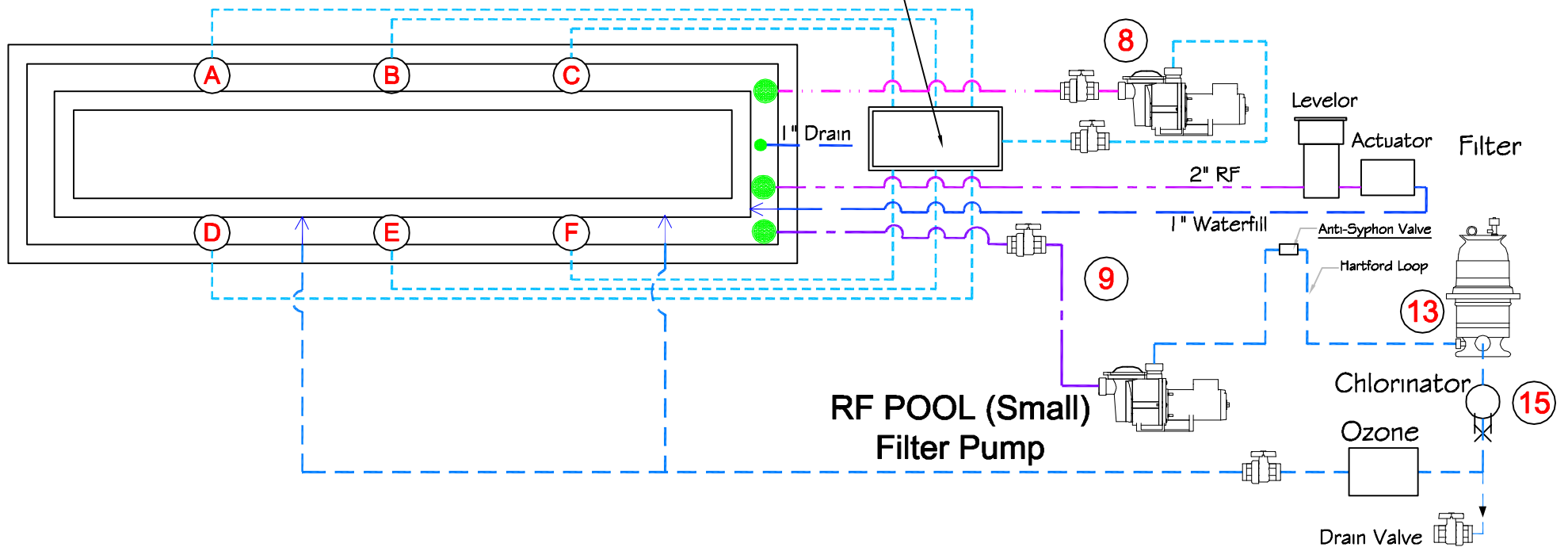

ALL DIMENSIONS SUBJECT TO 1/4" TOLERANCES

These drawings, concepts, and details contained herein are the original proprietary designs of NESPA ENTERPRISES, developed over many years of experience in the industry and as such are protected by the copyright laws of the United States Government. Reproduction of any of the above without written permission to do so by NESPA ENTERPRISES, is illegal.

NESPA ENTERPRISES INC.

2800 Richter Ave. Ste. C Oroville, CA 95966

Office: (530) 534-9910

Fax: (530) 534-9915

E-Mail: sales@tiledspas.com Web Site: www.tiledspas.com



If printing as a PDF:

Page Scaling: None

SCALE

3/8" = 1'

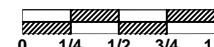

DWG NAME

6TH AVE PENTHOUSE_SMALL

DATE

10/5/2009

DWG TYPE

Plumbing Schematic

SHEET

PAGE 5 OF 9

Oct 05, 2009 - 9:25am

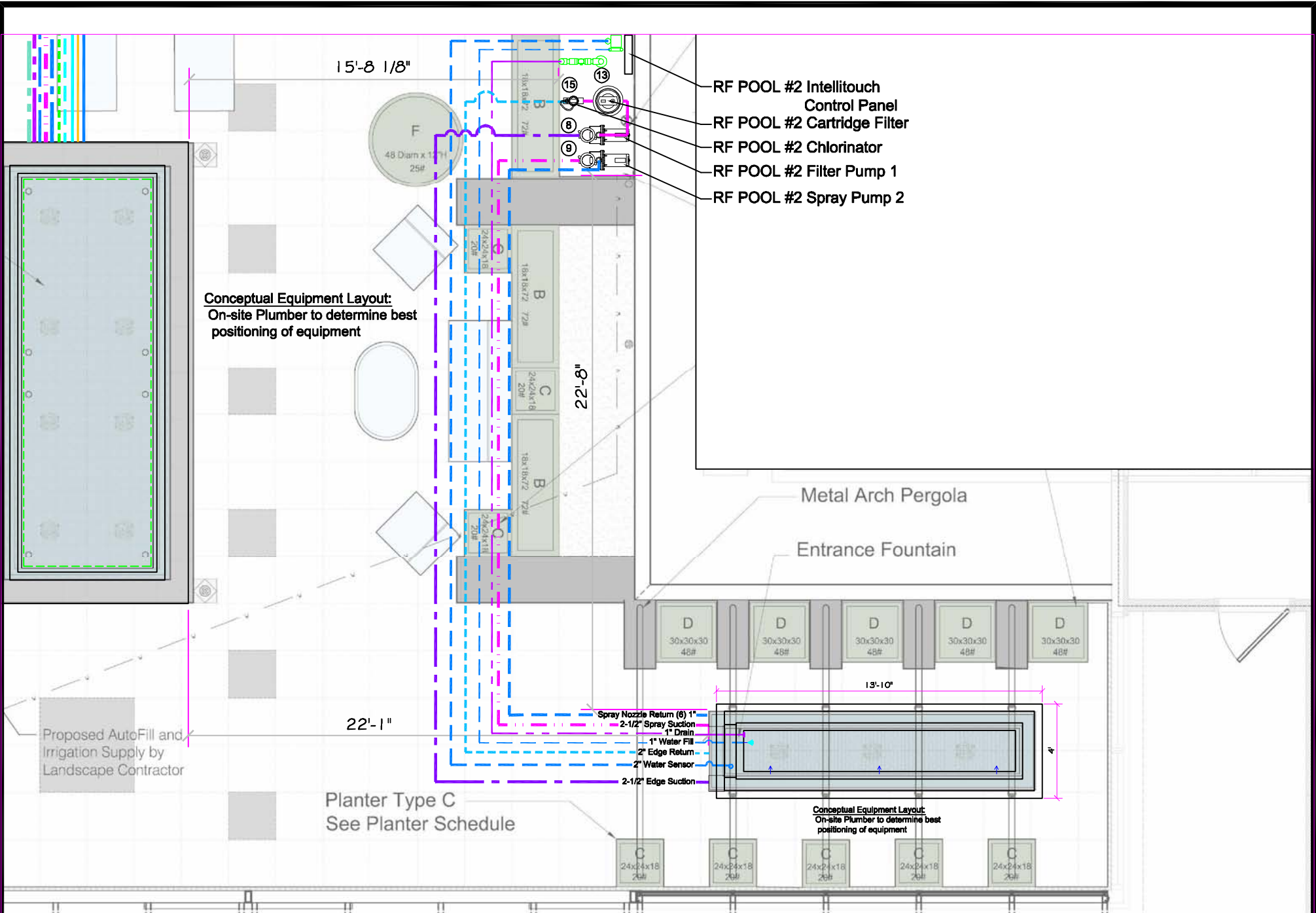

ALL DIMENSIONS SUBJECT TO 1/4" TOLERANCES

These drawings, concepts, and details contained herein are the original proprietary designs of NESPA ENTERPRISES, developed over many years of experience in the industry and as such are protected by the copyright laws of the United States Government. Reproduction of any of the above without written permission to do so by NESPA ENTERPRISES, is illegal.

NESPA ENTERPRISES INC.
 2800 Richter Ave. Ste. C Oroville, CA 95966
 Office: (530) 534-9910 Fax: (530) 534-9915
 E-Mail: sales@tiledspas.com Web Site: www.tiledspas.com



If printing as a PDF:
 Page Scaling:
 DWG NAME: 6TH AVE PENTHOUSE_SMALL

SCALE: 3/16" = 1'
 0 1/4 1/2 3/4 1"
 DATE: 7/31/2009

Oct 05, 2009 - 9:25am
 DWG TYPE: EQ Layout
 SHEET: PAGE 6 OF 9

NOTE:

THIS SCHEMATIC IS FOR CONCEPTUAL PURPOSES ONLY AND IS BASED ON SINGLE PHASE POWER INPUT. IF THREE PHASE POWER INPUT IS USED THEN CONSULT A LICENSED ELECTRICIAN AND COMPLY WITH ALL APPLICABLE NATIONAL AND LOCAL CODES.

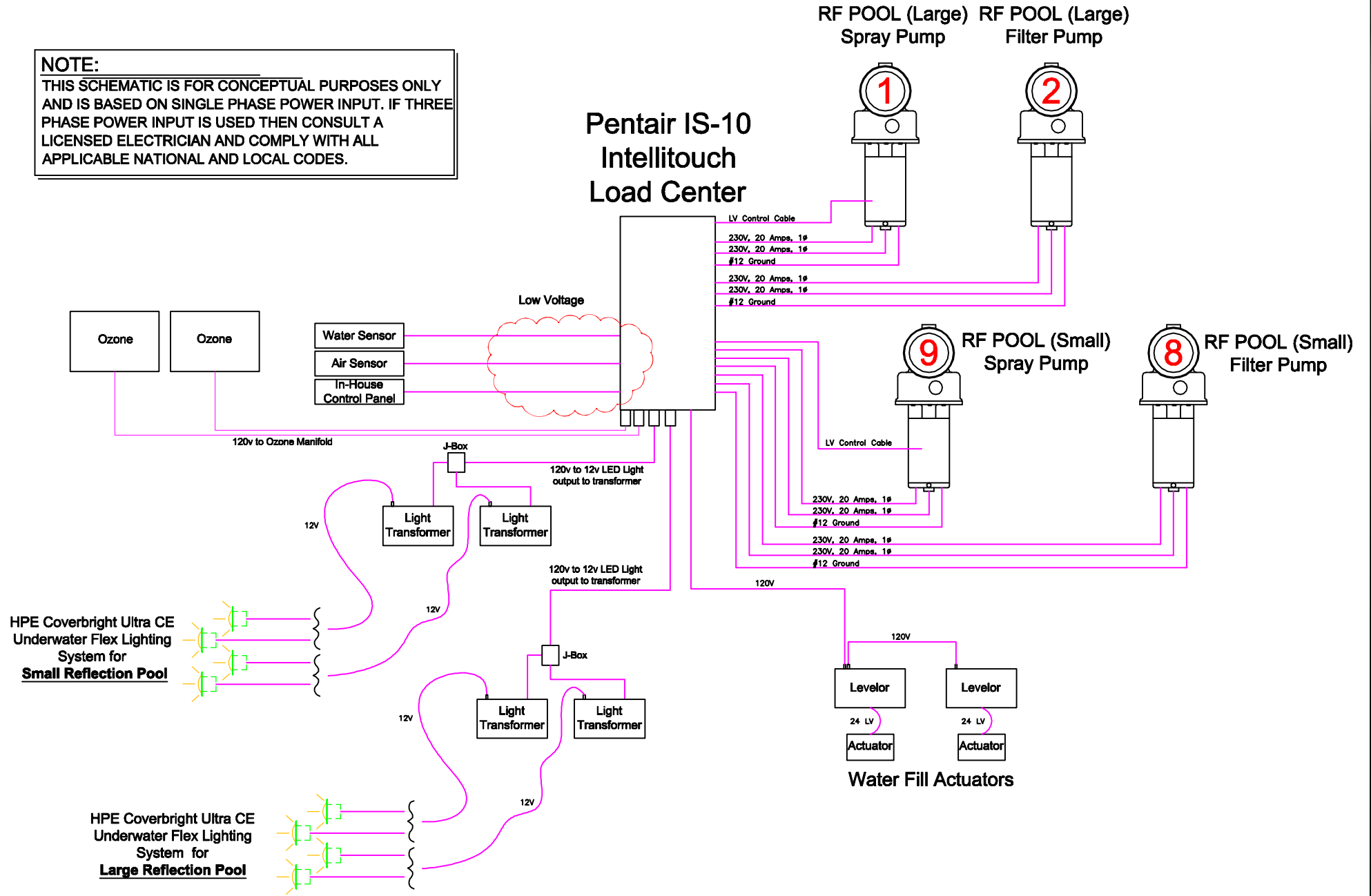

ALL DIMENSIONS SUBJECT TO 1/4" TOLERANCES

These drawings, concepts, and details contained herein are the original proprietary designs of NESPA ENTERPRISES, developed over many years of experience in the industry and as such are protected by the copyright laws of the United States Government. Reproduction of any of the above without written permission to do so by NESPA ENTERPRISES, is illegal.

NESPA ENTERPRISES INC.
 2800 Richter Ave. Ste. C Oroville, CA 95966
 Office: (530) 534-9910 Fax: (530) 534-9915
 E-Mail: sales@tiledspas.com Web Site: www.tiledspas.com



If printing as a PDF:
 Page Scaling: None

SCALE: N/A
 0 1/4 1/2 3/4 1"

Oct 05, 2009 - 9:25am
 DWG TYPE: Electrical
 SHEET: PAGE 7 OF 9

DWG NAME: 6TH AVE PENTHOUSE_SMALL
 DATE: 10/5/2009

- 3x12 Bullnose Edge
American Olean Catarina Series:
Coliseum White - C190
- 1x6 Band Tile (2 rows)
DalTile Glass Reflections:
Stratosphere Blue
- 3x12 Bullnose Edge
American Olean Catarina Series:
Coliseum White - C190
- 3x12 Bullnose Edge
American Olean Catarina Series:
Coliseum White - C190
- 1x6 Band Tile (2 rows)
DalTile Glass Reflections:
Stratosphere Blue
- 3x12 Bullnose Edge
American Olean Catarina Series:
Coliseum White - C190
- 6x6 Perimeter Basin
DalTile - Glass Mosaic Border:
Greek Key Five
- 1x1 Inner Basin
American Olean Catarina Series:
Coliseum White - C190
- 1x6 Band Tile (1 row)
DalTile - Glass Reflections:
Stratosphere Blue
- 1x1 Bottom Field
DalTile - Glass Reflections:
Caribbean Surf

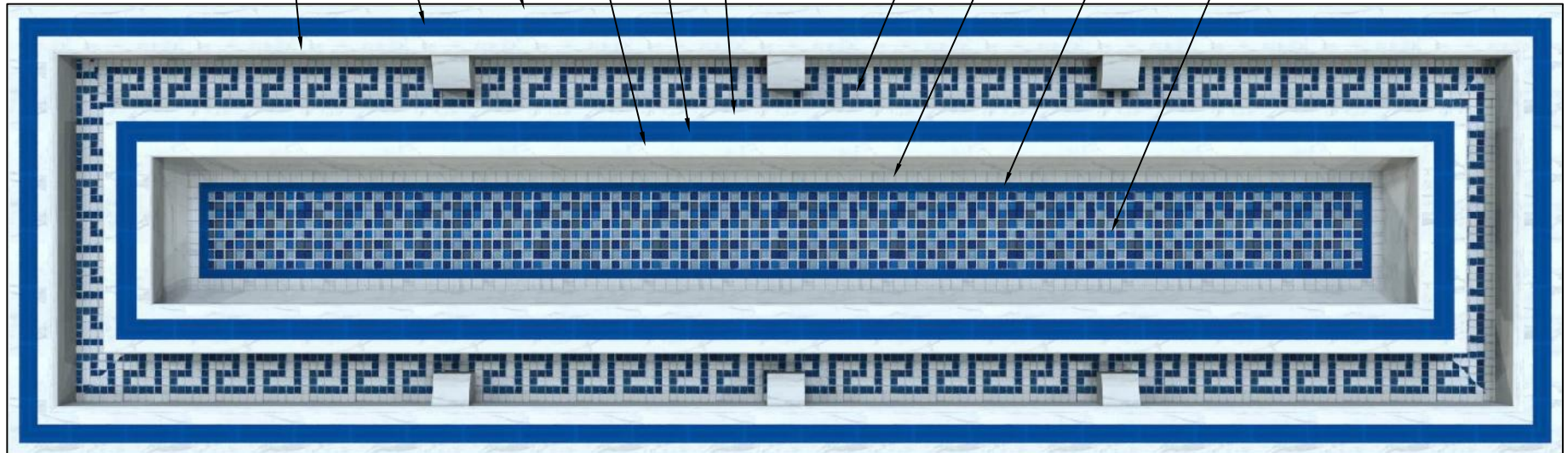

ALL DIMENSIONS SUBJECT TO 1/4" TOLERANCES

These drawings, concepts, and details contained herein are the original proprietary designs of NESPA ENTERPRISES, developed over many years of experience in the industry and as such are protected by the copyright laws of the United States Government. Reproduction of any of the above without written permission to do so by NESPA ENTERPRISES, is illegal.

NESPA ENTERPRISES INC.

2800 Richter Ave. Ste. C Oroville, CA 95966

Office: (530) 534-9910

Fax: (530) 534-9915

E-Mail: sales@tiledspas.com Web Site: www.tiledspas.com



If printing as a PDF:

Page Scaling:

SCALE

N/A



Oct 05, 2009 - 9:25am

DWG TYPE

Tile Detail

DWG NAME

6TH AVE PENTHOUSE_SMALL

DATE

8/3/2009

SHEET

PAGE 8 OF 9

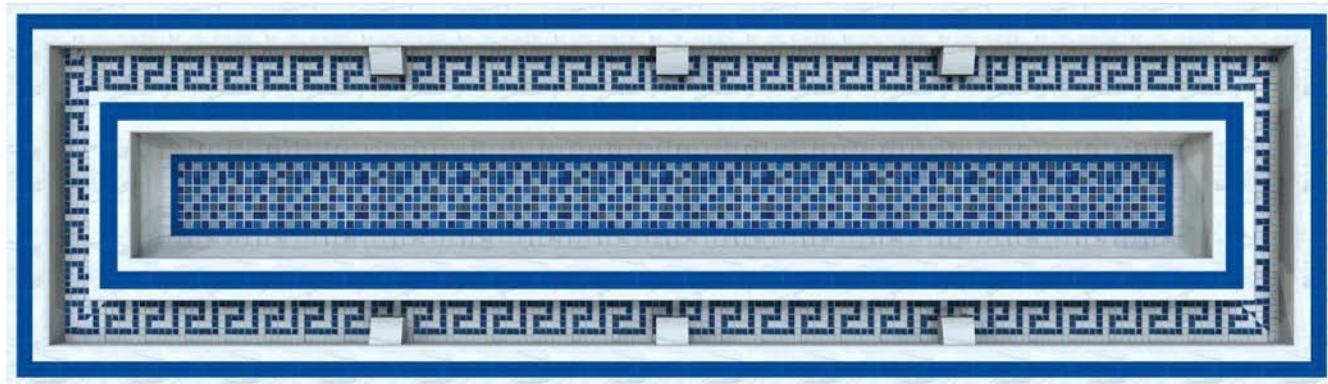
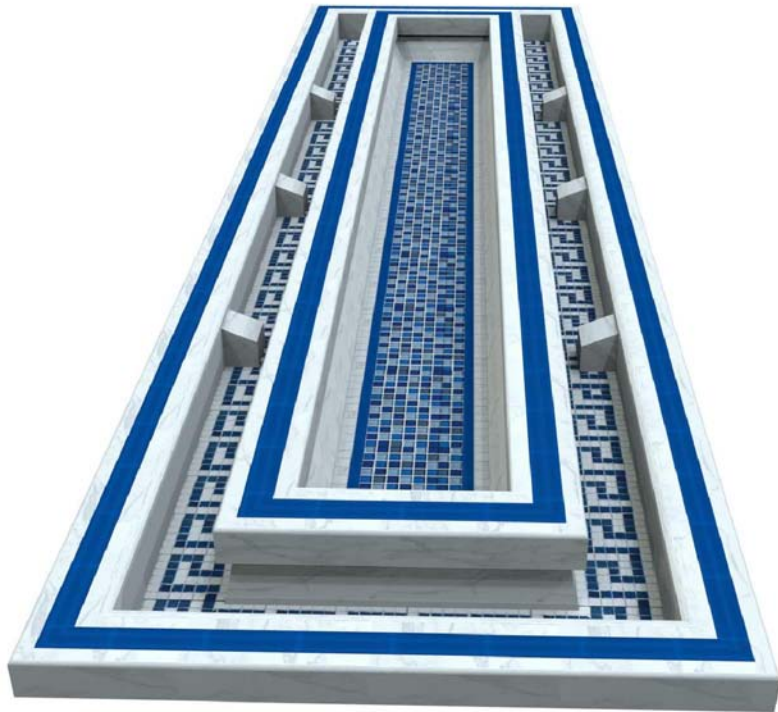

ALL DIMENSIONS SUBJECT TO 1/4" TOLERANCES

Oct 05, 2009 - 9:25am

These drawings, concepts, and details contained herein are the original proprietary designs of NESPA ENTERPRISES, developed over many years of experience in the industry and as such are protected by the copyright laws of the United States Government. Reproduction of any of the above without written permission to do so by NESPA ENTERPRISES, is illegal.

NESPA ENTERPRISES INC.

2800 Richter Ave. Ste. C Oroville, CA 95966

Office: (530) 534-9910

Fax: (530) 534-9915

E-Mail: sales@tiledspas.com

Web Site: www.tiledspas.com



If printing as a PDF:

Page Scaling:

SCALE

N/A

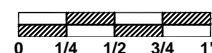

DWG TYPE

Render

DWG NAME

6TH AVE PENTHOUSE_SMALL

DATE

8/3/2009

SHEET

PAGE 9 OF 9



RECOMMENDED MAINTENANCE

Please Note:

These are only recommended guidelines to care for a Nespa all tiled spa. Local codes may require additional procedures, therefore consult with a pool professional that is LA county Health Department certified for more information on local codes and requirements.

SPA SURFACE

Your spa tile is acid resistant and frost-proof. The Tile does not absorb germs or algae. Tile does not stain and is very easy to clean. Color does not fade or lose its luster. All grouts are epoxy based and are extremely durable. To remove scum line use soft nylon brush and small amounts of biodegradable soaps. Do not use abrasive brushes or chemicals.

MAINTENANCE

A. CHEMICALS:

- 1) It is important to maintain a chlorine residual of 2 PPM in the spa. That residual can be provided by chlorine or bromine.
- 2) It is recommended to use Bromine or dichlor (granular) forms of chlorine. If bromine Tabs are used we suggest floating or inline dispenser.
- 3) Never use acid to lower Ph in the tile spa.
- 4) Never use trichlor chlorine (1" or 3") tablets in the Nespa spas.
- 5) Never place tablets in skimmer basket.

B. DRAINING THE SPA:

- 1) It is recommended to drain the spa at least once every 2 months depending on bath load and water clarity.
- 2) The spa should be drained through valve exiting re-circulation pump in the spa equipment room or sump pump.
- 3) Note: Use caution to drain spa in the winter months or rainy season when water table is at its highest. It is possible for the spa to float due to hydraulic pressure from surrounding water table. We advise that you consult with your local spa specialist prior to draining the spa.

C. SPA EQUIPMENT:

- 1) Clean filter cartridge at least once every month, or when needed; i.e., if water clarity does not improve after several days.
- 2) Keep area free and clear from leaves and debris build-up.
- 3) Keep area free and clear from flooding.

D. SPA LIGHT:

- 1) Spa light has to be on GFCI circuit. It is controlled at spa side with ON/OFF.

E. TILE SERVICING:

- 1) Contact manufacture when servicing tile or grout. @ (530) 534-9910