



**NESPA**  
TILED SPAS

# **Production Booklet**

**for**

## **KROENKE SPA**

2800 Richter Ave. Suite C, Oroville, CA 95965 • **voice:** (530)534-9910  
**fax:** (530)534-9915 • **email:** sales@tiledspas.com • **website:** www.tiledspas.com



## RECOMMENDED MAINTENANCE

### *Please Note:*

These are only recommended guidelines to care for a Nespa all tiled spa. Local codes may require additional procedures, therefore consult with a pool professional that is LA county Health Department certified for more information on local codes and requirements.

### **SPA SURFACE**

Your spa tile is acid resistant and frost-proof. The Tile does not absorb germs or algae. Tile does not stain and is very easy to clean. Color does not fade or lose its luster. All grouts are epoxy based and are extremely durable. To remove scum line use soft nylon brush and small amounts of biodegradable soaps. Do not use abrasive brushes or chemicals.

### MAINTENANCE

#### **A. CHEMICALS:**

- 1) It is important to maintain a chlorine residual of 2 PPM in the spa. That residual can be provided by chlorine or bromine.
- 2) It is recommended to use Bromine or dichlor (granular) forms of chlorine. If bromine Tabs are used we suggest floating or inline dispenser.
- 3) Never use acid to lower Ph in the tile spa.
- 4) Never use trichlor chlorine (1" or 3") tablets in the Nespa spas.
- 5) Never place tablets in skimmer basket.

#### **B. DRAINING THE SPA:**

- 1) It is recommended to drain the spa at least once every 2 months depending on bath load and water clarity.
- 2) The spa should be drained through valve exiting re-circulation pump in the spa equipment room or sump pump.
- 3) Note: Use caution to drain spa in the winter months or rainy season when water table is at its highest. It is possible for the spa to float due to hydraulic pressure from surrounding water table. We advise that you consult with your local spa specialist prior to draining the spa.

#### **C. SPA EQUIPMENT:**

- 1) Clean filter cartridge at least once every month, or when needed; i.e., if water clarity does not improve after several days.
- 2) Keep area free and clear from leaves and debris build-up.
- 3) Keep area free and clear from flooding.

#### **D. SPA LIGHT:**

- 1) Spa light has to be on GFCI circuit. It is controlled at spa side with ON/OFF.

#### **E. TILE SERVICING:**

- 1) Contact manufacture when servicing tile or grout. @ (530) 534-9910

# PLAN APPROVAL DOCUMENTATION

**APPROVED**

## DRAWING REVISION HISTORY

### SHEET 1 - SD (Spa Detail)

REV NOTE:

### SHEET 2 - Tile Detail

REV NOTE:

### SHEET 3 - Plumbing

REV NOTE:

### SHEET 4 - Engineering

REV NOTE:

### SHEET 5 - Drain Detail)

REV NOTE:

### SHEET 6 - IAPMO

REV NOTE:

### SHEET 7 - Installation

REV NOTE:

### SHEET 8-10 - Render

REV NOTE:

I approve the above drawings X \_\_\_\_\_ Date: \_\_\_\_\_

Any changes to these plans from here forward shall be directed in writing to Nespa.

## SPA FABRICATION AUTHORIZATION

Nespa's engineering and structural manufacturing departments may find it necessary to make slight adjustments (= 1") to your spa.

This may include the size of the spa (OD/ID), tile cuts, depths, jet location, bench steps etc. These adjustments must be made in the primary stages of building the spa. The adjustments are generally made to ad structural and aesthetic integrity to the vessel. IE: balance of supporting gussets (exterior) and less tile cuts/ symmetrical cuts, grout lines, etc. (interior)

### Please initial next to the following number that describes your project needs .

- \_\_\_\_\_ 1. YES, I understand adjustments need to be made. Nespa will use their expertise to make these adjustments as needed. I give them the authority to make changes. I will receive final accurate drawings prior to receipt of spa or spa hole construction (if changes were made to the size)
- \_\_\_\_\_ 2. NO, No changes can be made even under 1". Dimensions are fixed. More tile cuts may be needed, Structural supports may be altered to accommodate.
- \_\_\_\_\_ 3. Nespa will need to contact us for any changes to spa dimensions prior to continued spa fabrication.

### **NESPA ENTERPRISES INC.**

2800 Richter Ave. Suite C Oroville, CA 95966

Office: (530) 534-9910

Fax: (530) 534-9915

E-Mail: [jim@tiledspas.com](mailto:jim@tiledspas.com) Web Site: [www.tiledspas.com](http://www.tiledspas.com)



### **If printing as a PDF:**

Page Scaling:

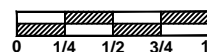

DWG TYPE

Revisions

DWG NAME

KROENKE

DATE

9/29/2010

SHEET

Cover Sheet

These drawings, concepts, and details contained herein are the original proprietary designs of NESPA ENTERPRISES, developed over many years of experience in the industry and as such are protected by the copyright laws of the United States Government. Reproduction of any of the above without written permission to do so by NESPA ENTERPRISES, is illegal.

SPECIFICATIONS	
DRY WEIGHT:	2600 LBS.
TOTAL WEIGHT:	11892 LBS.
WATER:	1114.5 GAL.
VOLUME:	149 Cu.Ft.
WEIGHT:	9292 LBS.
SURFACE AREA:	64 SQ. FT.
IAPMO#:	1138
FDA#:	2030305

<b>SKID SUPPORT STRUCTURE* BONDED TO SPA</b>	
*SKIDS SUPPLIED BY NESPA	
<b>LIGHT NICHE</b>	
	SPA BRIGHT, 120 V, 100 WATT, 50' CORD, U.L. APPROVED
<b>SIDEWALL SUCTION</b>	
	AquaStar 10AV, 10" Dia Frame, Approved Max Flow Rate: Floor = 206 GPM @ 5.8 fps, Wall = 96 GPM @ 2.8 fps, Max Flow = 210GPM, V.G.B Approved, Safety Drain
<b>MAIN DRAIN</b>	
	AquaStar 10AV, 10" Dia Frame, Approved Max Flow Rate: Floor = 206 GPM @ 5.8 fps, Wall = 96 GPM @ 2.8 fps, Max Flow = 210GPM, V.G.B Approved, Safety Drain
<b>SKIMMER</b>	
	FRONT ACCESS SKIMMER, NSF APPROVED
<b>JET</b>	
	HYDRO INLETS, 1-1/2" WATER - 1-1/2" AIR, HYDROAIR #10-5100, COMPLIES W/ ANSI CODE ASME A112.19.8-07, UL APPROVED
<b>RETURN</b>	
	INLET FITTINGS, 1-1/2" WALL TYPE W/ EYEBALL, HYDROAIR #10-3500, COMPLIES W/ ANSI CODE ASME A112.19.8-07, UL APPROVED
<b>FILL</b>	
	INLET FITTINGS, 1-1/2" WALL TYPE W/ EYEBALL, HYDROAIR #10-3500, COMPLIES W/ ANSI CODE ASME A112.19.8-07, UL APPROVED

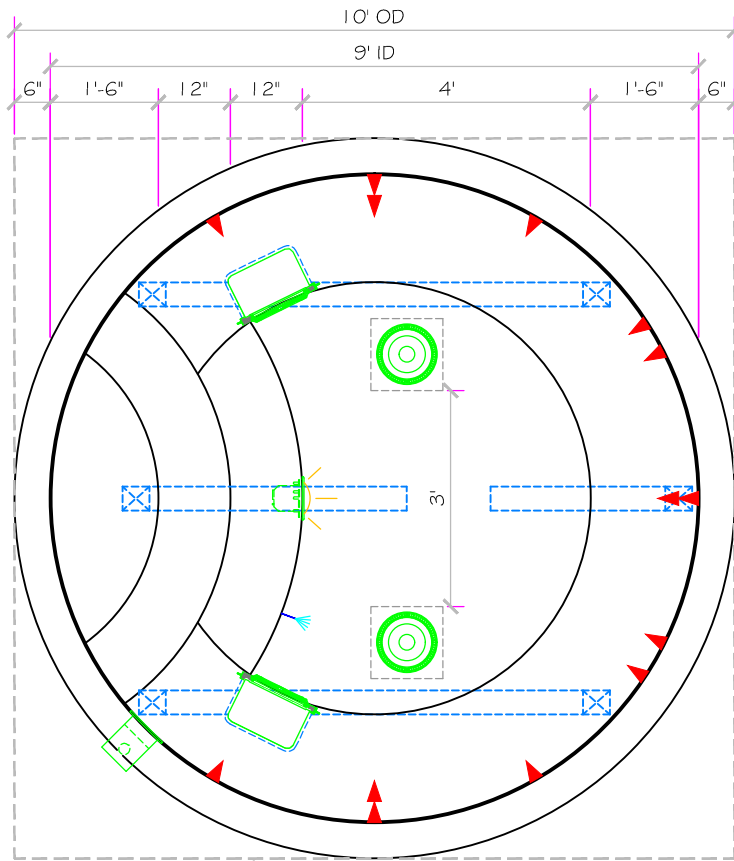

10' X 10' Support Pad  
Depth to be determined by Engineer

2" Coping by others

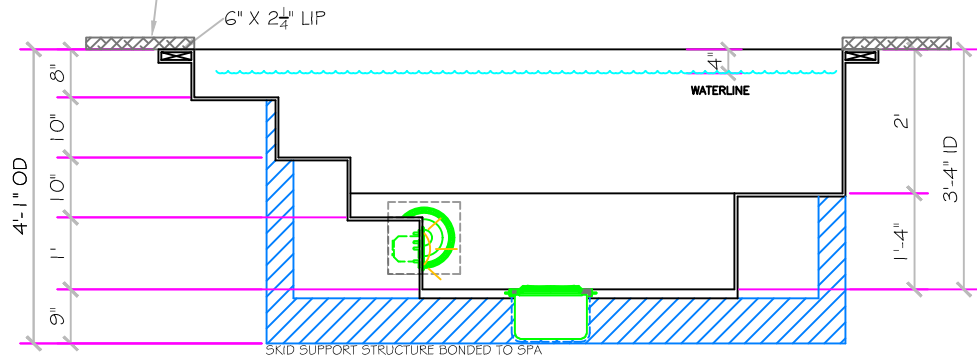

**APPROVED**

\*ALL DIMENSIONS SUBJECT TO 1/4" TOLERANCES\*

**NESPA ENTERPRISES INC.**

2800 Richter Ave. Suite C Oroville, CA 95966

Office: (530) 534-9910

Fax: (530) 534-9915

E-Mail: [jim@tiledspas.com](mailto:jim@tiledspas.com) Web Site: [www.tiledspas.com](http://www.tiledspas.com)



If printing as a PDF:

Page Scaling:

SCALE  
3/8" = 1'

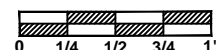

DWG TYPE

SD

DWG NAME  
KROENKE

DATE  
9/29/2010

SHEET  
PAGE 1 OF 10

These drawings, concepts, and details contained herein are the original proprietary designs of NESPA ENTERPRISES, developed over many years of experience in the industry and as such are protected by the copyright laws of the United States Government. Reproduction of any of the above without written permission to do so by NESPA ENTERPRISES, is illegal.

#1 - FIELD TILE: Dal Tile - SR85 - Sonterra Navy Blue Iridescent  
 #2 - WATERLINE (optional): Dal Tile - SR85 - Sonterra Navy Blue Iridescent  
 #3 - BENCH & STEP EDGES (optional): \_\_\_\_\_  
 #4 - TILED LIP (optional): Coping (by others)

Date: \_\_\_\_\_  
 Approval: \_\_\_\_\_

#1 - GROUT: \_\_\_\_\_  
 #2 - GROUT: \_\_\_\_\_  
 #3 - GROUT: \_\_\_\_\_

64 Sq. Ft. Horizontal Tile  
 81 Sq. Ft. Vertical Tile

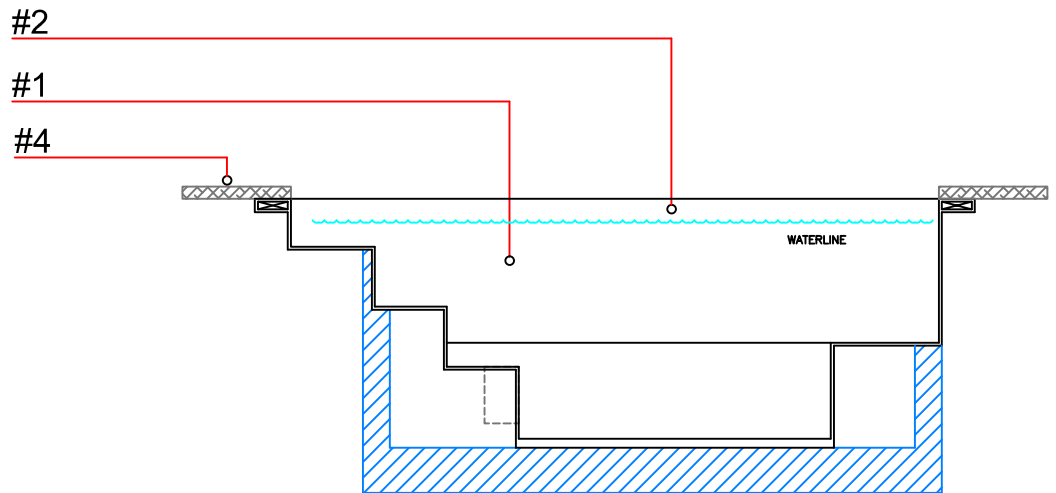
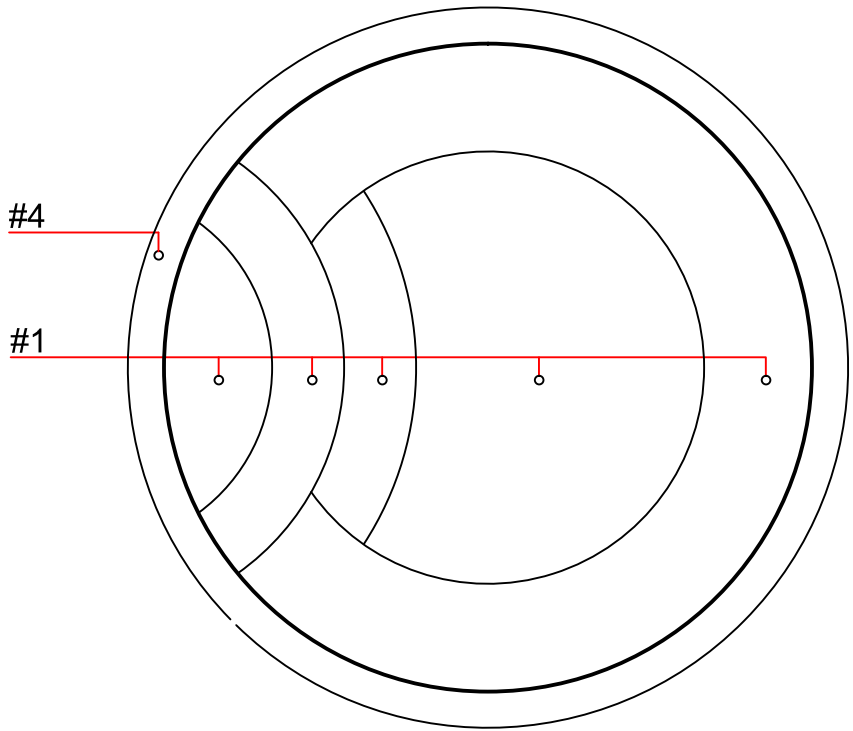

**APPROVED**

\*ALL DIMENSIONS SUBJECT TO 1/4" TOLERANCES\*

**NESPA ENTERPRISES INC.**  
 2800 Richter Ave. Suite C Oroville, CA 95966  
 Office: (530) 534-9910 Fax: (530) 534-9915  
 E-Mail: [jim@tiledspas.com](mailto:jim@tiledspas.com) Web Site: [www.tiledspas.com](http://www.tiledspas.com)



**If printing as a PDF:**  
 Page Scaling:   
 DWG NAME: **KROENKE**

SCALE: 3/8" = 1'  
 DATE: 8/31/2010

DWG TYPE: Tile  
 SHEET: PAGE 2 OF 10

These drawings, concepts, and details contained herein are the original proprietary designs of NESPA ENTERPRISES, developed over many years of experience in the industry and as such are protected by the copyright laws of the United States Government. Reproduction of any of the above without written permission to do so by NESPA ENTERPRISES, is illegal.

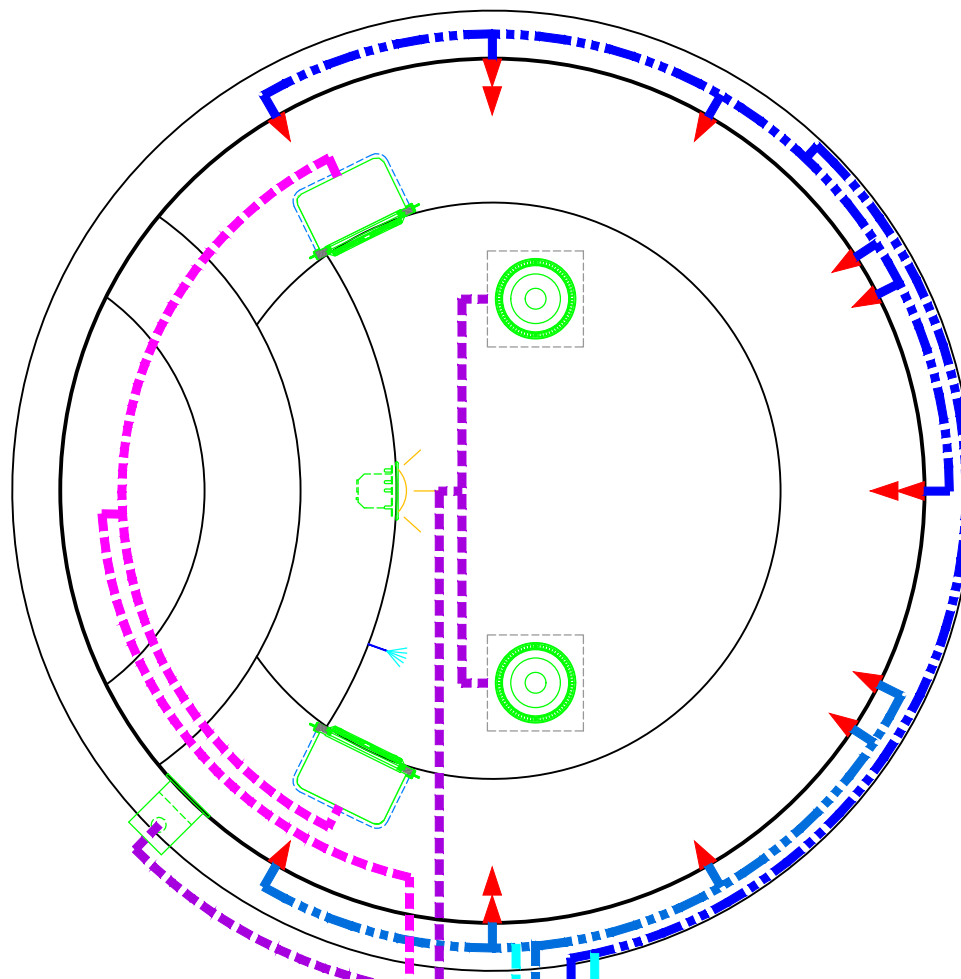

1-1/2" Skimmer Suction

3" Booster Suction

2-1/2" Filter Suction

2" Air Venturi

2-1/2" Booster Return

2" Filter Return

2" Air Venturi

**ALL FITTINGS TO BE BLACK**

**APPROVED**

\*ALL DIMENSIONS SUBJECT TO 1/4" TOLERANCES\*

These drawings, concepts, and details contained herein are the original proprietary designs of NESPA ENTERPRISES, developed over many years of experience in the industry and as such are protected by the copyright laws of the United States Government. Reproduction of any of the above without written permission to do so by NESPA ENTERPRISES, is illegal.

**NESPA ENTERPRISES INC.**

2800 Richter Ave. Ste. C Oroville, CA 95966

Office: (530) 534-9910

Fax: (530) 534-9915

E-Mail: [jim@tiledspas.com](mailto:jim@tiledspas.com) Web Site: [www.tiledspas.com](http://www.tiledspas.com)



**If printing as a PDF:**

Page Scaling:

SCALE

1/2" = 1'

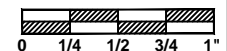

DWG TYPE

Plumbing

DWG NAME

KROENKE

DATE

9/29/2010

SHEET

PAGE 3 OF 10

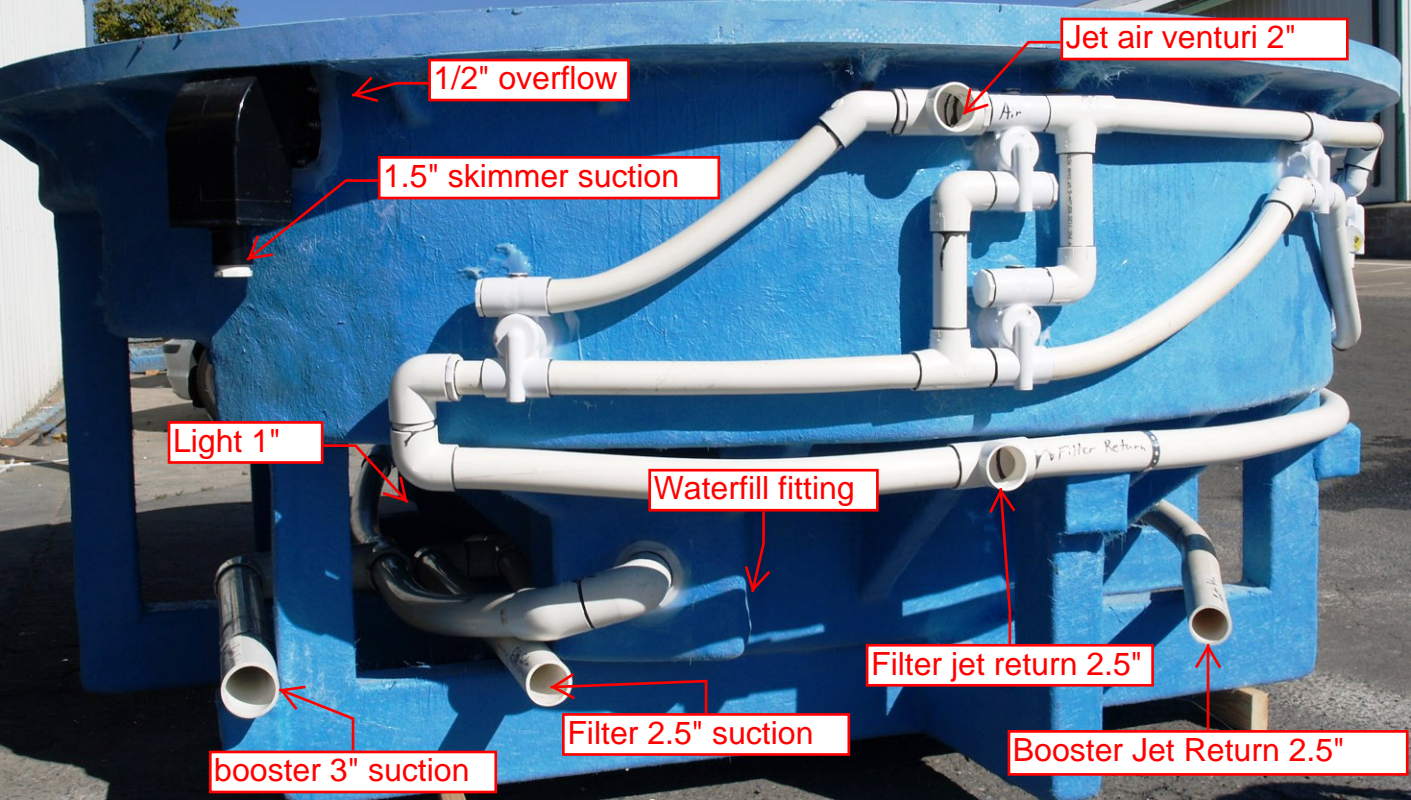

1/2" overflow

Jet air venturi 2"

1.5" skimmer suction

Light 1"

Waterfill fitting

Filter jet return 2.5"

booster 3" suction

Filter 2.5" suction

Booster Jet Return 2.5"

# NESPA Enterprises, Inc.

BY: L.J. Garcia

SUBJECT: Basin Design

MATERIAL: Fiberglass

Min. Properties

$$F_b = 28,000 \text{ PSI}$$

$$F_t = 18,000 \text{ PSI}$$

$$E = 890,000 \text{ PSI}$$

Wall Design:  
(Check Imperia)  
Use 3/8" wall

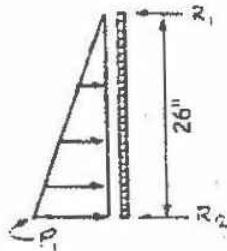

STIFFENER →  
(TYP. ALL WALLS)

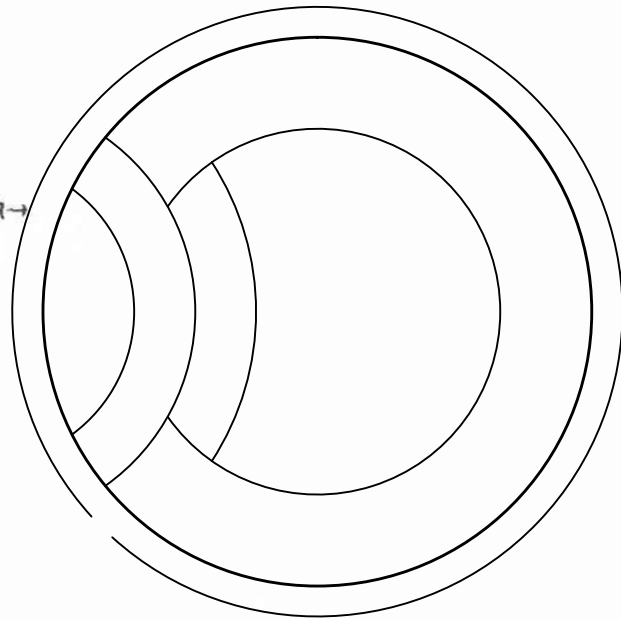

$$P = 62.4 \text{ \#/ft.}^2$$

$$P_1 = 62.4 \times 29/12 = 150.0 \text{ \#/ft.}$$

M max at 0.577 l

$$M_{max} = 0.0641 P_1 l^2$$

$$= 0.0641 \times 62.4 \times \frac{(29)^3}{(12)^3} = 56.5 \text{ \#}$$

$$S = \frac{bd^2}{3} = 12 \times \frac{0.375^2}{6}$$

$$= 0.28 \text{ in}^3/\text{ft}$$

$$f_b = \frac{M}{S} = \frac{56.5 \times 12}{0.28} = 2,421 \text{ psi}$$

$$F_b = 28,000 \text{ PSI}$$

$$F.S. = F_b / f_b = \frac{28,000}{2,421}$$

$$= 11.6$$

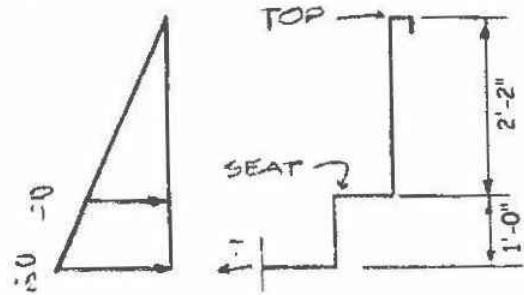
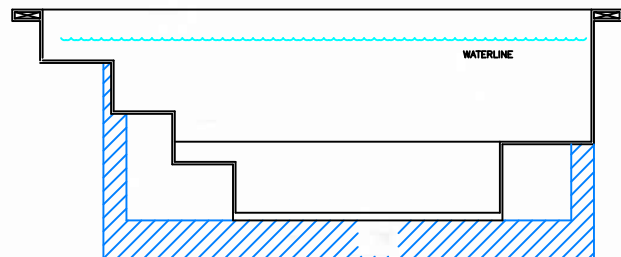

part. elev

*Louis J. Garcia*

P.E. No. License C 026991

Custom Handpainted Ceramic Tiles

Ceramic Tile Spas & Bathubs

**APPROVED**

\*ALL DIMENSIONS SUBJECT TO 1/4" TOLERANCES\*

**NESPA ENTERPRISES INC.**

2800 Richter Ave. Suite C Oroville, CA 95966

Office: (530) 534-9910

Fax: (530) 534-9915

E-Mail: [jim@tiledspas.com](mailto:jim@tiledspas.com) Web Site: [www.tiledspas.com](http://www.tiledspas.com)



If printing as a PDF:

Page Scaling:

SCALE

N/A

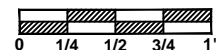

DWG TYPE

Engineering

DWG NAME

KROENKE

DATE

8/4/2010

SHEET

PAGE 4 OF 10

These drawings, concepts, and details contained herein are the original proprietary designs of NESPA ENTERPRISES, developed over many years of experience in the industry and as such are protected by the copyright laws of the United States Government. Reproduction of any of the above without written permission to do so by NESPA ENTERPRISES, is illegal.



# 10" Anti-Entrapment Suction Outlet Cover and Frame

## VGB Series

### Product Specification Sheet

The AquaStar line of suction outlet covers, compliant with the new Virginia Graeme-Baker Pool and Spa Safety Act (ASME/ANSI A112.19.8a-2008)

#### Features

For single or multiple drain use.  
(see installation instructions)

Requires a minimum 3" sump depth

#### Single

Floor: 206 GPM at 5.8 fps

Wall: 96 GPM at 2.8 fps

Floor/wall: 53 GPM at 1.5 fps

11.2 square inch opening

#316 stainless steel screws

Manufactured from superior UV-resistant engineered polymers

Meets or exceeds NSF 50/ASME/ANSI A112.19.8a-2008 national standards and ASTM G154 UV testing

Listed with IAPMO R&T

25 per case



Part # 10AVXXX

Also fits: 10" Waterway and Color Match

#### Part Numbers / Colors

- 10AV101 White
- 10AV102 Black
- 10AV103 Lt. Gray
- 10AV104 Blue
- 10AV105 Dk. Gray
- 10AV106 Bone
- 10AV107 Taupe
- 10AV108 Tan

VGB 2008 Compliant

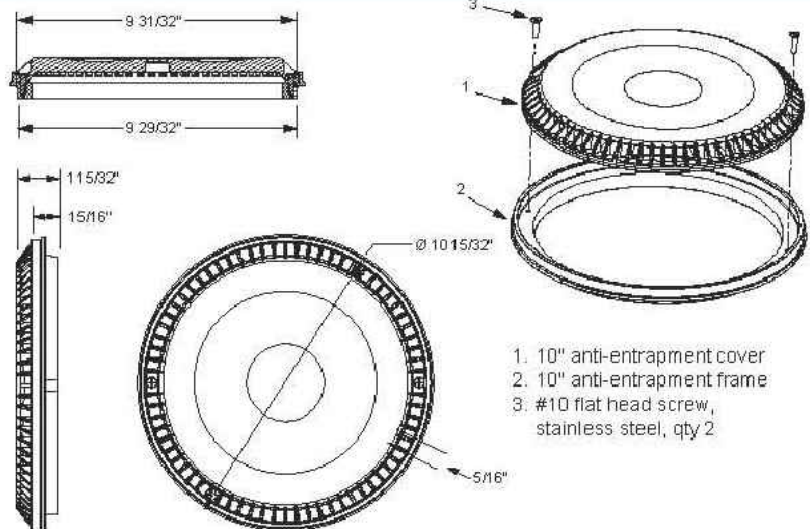

1. 10" anti-entrapment cover
2. 10" anti-entrapment frame
3. #10 flat head screw, stainless steel, qty 2

**APPROVED**

P 877-768-2717 F 877-276-POOL Outside the US: P +1-949-459-1202 F +1-949-336-1940  
info@aquastarpoolproducts.com www.aquastarpoolproducts.com

\*ALL DIMENSIONS SUBJECT TO 1/4" TOLERANCES\*

**NESPA ENTERPRISES INC.**

2800 Richter Ave. Suite C Oroville, CA 95966

Office: (530) 534-9910

Fax: (530) 534-9915

E-Mail: [jim@tiledspas.com](mailto:jim@tiledspas.com) Web Site: [www.tiledspas.com](http://www.tiledspas.com)



If printing as a PDF:

Page Scaling:

SCALE

N/A

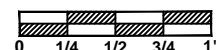

DWG TYPE

Drain Detail

DWG NAME

KROENKE

DATE

8/4/2010

SHEET

PAGE 5 OF 10

# IAPMO RESEARCH AND TESTING, INC.

5001 East Philadelphia Street, Ontario, California 91761-2816 • (909) 472-4100 Fax (909) 472-4244 • www.iapmo.org



## CERTIFICATE OF LISTING

IAPMO Research and Testing, Inc. is a product certification body which tests and inspects samples taken from the supplier's stock or from the market or a combination of both to verify compliance to the requirements of applicable codes and standards. This activity is coupled with periodic surveillance of the supplier's factory and warehouses as well as the assessment of the supplier's Quality Assurance System. This listing is subject to the conditions set forth in the characteristics below and is not to be construed as any recommendation, assurance or guarantee by IAPMO Research and Testing, Inc. of the product acceptance by Authorities Having Jurisdiction.

Effective Date: September 2010      Void After: September 2011  
 Product: Spa Shell (Tile Lined FRP)      File No. SP-1138  
 Issued To: Nespa, Inc.  
 2800 Richter Ave Unit#e  
 Oroville, CA 95966

IDENTIFICATION: The manufacturer's name or trademark, or both, and the USPC® certification mark shall be permanently and legibly marked on the unit so as to be visible after installation. A label shall be permanently affixed to each unit in a visible location and shall include the manufacturer's name and/or trademark, and model designation. Units manufactured as "Shell Only" shall be so identified and labeled. Unit shall be permitted to be marked "ANSI Z124.7" signifying compliance with this standard.

*David McHenry*  
 Chairman, Product Certification Committee

*Russ Chaney*  
 CEO, The IAPMO Group



For the most accurate and updated information please visit <http://pfd.iapmo.org/SP-1138>

This listing is for the period indicated herein and is void after the date shown above. Any change in material, manufacturing process, marking or design without having first obtained the approval of the Product Certification Committee, or any evidence of non-compliance with applicable codes and standards or of inferior workmanship, may be deemed sufficient cause for revocation of this listing. Reproduction of or reference to this form for advertising purposes may be made only by specific written permission of IAPMO Research and Testing, Inc. Any alteration of this certificate could be grounds for revocation of the listing.

DOC#081A



# IAPMO RESEARCH AND TESTING, INC. CERTIFICATE OF LISTING

Page 3

Void After: September 2011

File No. SP-1138

Product: Spa Shell (Tile Lined FRP)

Issued To: Nespa, Inc.

MODELS:

- |                  |                    |
|------------------|--------------------|
| Acapulco         | Mirage 11'         |
| Acapulco II      | Mirage 13'         |
| Acapulco III     | Mirage 15'         |
| Acapulco IV      | Mirage 17'         |
| Blackthorne      | Mirage 9'          |
| Capri            | Monaco             |
| Caribbean        | Nespa Swim Spa-12' |
| Corsica          | Nespa Swim Spa-16' |
| Corsica-Modified | Nespa Swim Spa-18' |
| Eight Ft. Round  | Nespa Swim Spa-20' |
| Imperia          | Rimini             |
| Imperia II       | Rimini Commercial  |
| Kidney*          | Round* 11'         |
| Legacy 10'       | Round* 7'          |
| Legacy 12'       | Round* 9'          |
| Legacy 14'       | Serenity* 12'      |
| Legacy 16'       | Six Ft. Round      |
| Legacy 18'       | Tahoe*             |
| Legacy 20'       | Ten Ft. Round      |
| Maxima           | Vallarta           |

Note: Models with an "\*" indicate that the tile size must be 2" x 2"

DOC#081A

# APPROVED

\*ALL DIMENSIONS SUBJECT TO 1/4" TOLERANCES\*

These drawings, concepts, and details contained herein are the original proprietary designs of NESPA ENTERPRISES, developed over many years of experience in the industry and as such are protected by the copyright laws of the United States Government. Reproduction of any of the above without written permission to do so by NESPA ENTERPRISES, is illegal.

**NESPA ENTERPRISES INC.**  
 2800 Richter Ave. Ste. C Oroville, CA 95966  
 Office: (530) 534-9910      Fax: (530) 534-9915  
 E-Mail: [jim@tiledspas.com](mailto:jim@tiledspas.com)      Web Site: [www.tiledspas.com](http://www.tiledspas.com)



If printing as a PDF:

Page Scaling:

DWG NAME: KROENKE

SCALE: N/A

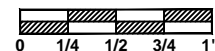

DATE: 8/4/2010

DWG TYPE: IAPMO  
 SHEET: PAGE 6 OF 10

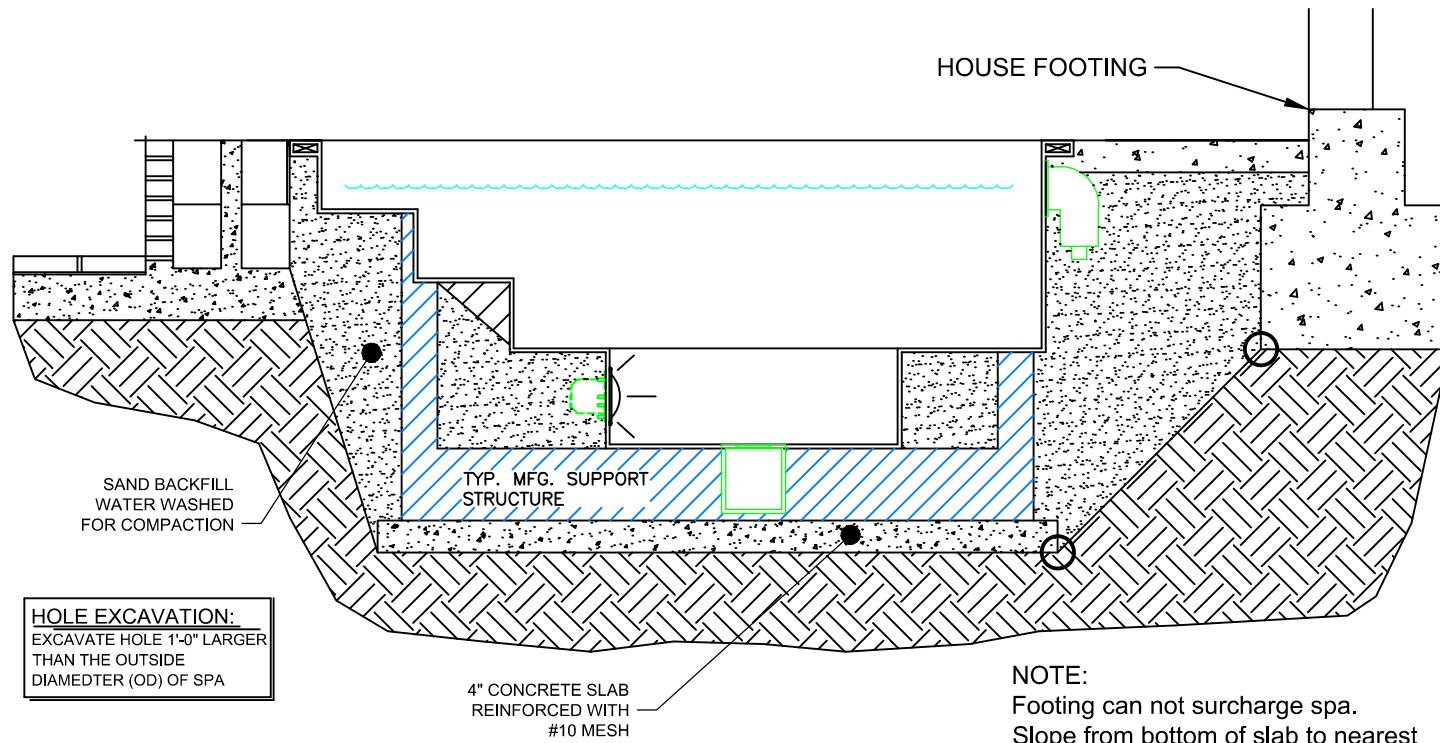

**HOLE EXCAVATION:**  
EXCAVATE HOLE 1'-0" LARGER  
THAN THE OUTSIDE  
DIAMETER (OD) OF SPA

**NOTE:**  
Footing can not surcharge spa.  
Slope from bottom of slab to nearest  
corner of house footing must not  
exceed 1" = 1".

## RESIDENTIAL SPA INSTALLATION RI-2

**APPROVED**

\*ALL DIMENSIONS SUBJECT TO 1/4" TOLERANCES\*

These drawings, concepts, and details contained herein are the original proprietary designs of NESPA ENTERPRISES, developed over many years of experience in the industry and as such are protected by the copyright laws of the United States Government. Reproduction of any of the above without written permission to do so by NESPA ENTERPRISES, is illegal.

**NESPA ENTERPRISES INC.**  
2800 Richter Ave. Ste. C Oroville, CA 95966  
Office: (530) 534-9910 Fax: (530) 534-9915  
E-Mail: [jim@tiledspas.com](mailto:jim@tiledspas.com) Web Site: [www.tiledspas.com](http://www.tiledspas.com)



**If printing as a PDF:**

Page Scaling:

DWG NAME

KROENKE

SCALE  
N/A

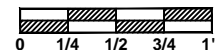

DATE

8/4/2010

DWG TYPE

Installation

SHEET

PAGE 7 OF 10

**STANDARD NESPA  
IN-GROUND INSTALLATION  
INSTRUCTIONS  
SET-UP AND EXCAVATION**

**Prerequisites:** Before installing your Nespa spa. You may be required to acquire a permit from your local State, County, and City building dept and or Health department. (Commercial jobs need Health Dept. Approval). Your spa installation must comply with the most current codes. ( **Uniform Swimming Pool, Spas & Hot Tub Code 2006 ( USPC 2006)**).

**Spa drawings:** Request from Nespa a current spa specific construction detail, plan and section, spa plumbing detail.

**Delivery Access:** Clearly determine the method of getting the spa to jobsite and into the hole. This may require the use of a crane, forklift, hoist, backhoe and/or manpower etc.

- 1) The following instructions are general guidelines and may not apply to your specific jobsite conditions. When excavating for your spa remember to provide for plumbing and light connection clearances. In order to determine how to excavate for your spa or swim spa, measure spas outside dimension ( O.D.) and add minimum 3” to all sides. This 3” clearance is to accommodate jet and suction plumbing. This 3” clearance can change or be reduced upon request. Note: skimmer location, this area may have to be larger than 3”, if commercial 22”.
- 2) **Freeze Climates-** If the spa is place into a vault (typical of freeze climates) a standard 18” or more of clearance minimum from spa perimeter should be provided. This dead air space is for possible future access to spa plumbing in case of a freeze. Area drain is mandatory. **Ask your local installer** for his experienced opinion. Do not hesitate to call us because we want to be sure that your installation progresses as smoothly as possible. If you have questions call us. (888) 479-4677.
- 2) **Hole depth** is determined by spa’s outside height dimension. This height may vary depending if spa has skids or no skids. The spa lip may be finished or non- finished. How is the perimeter deck elevation transitioning to the spa? Focus on the finish surrounding deck elevations, thickness of the finish material on spa upper horizontal lip, equal to lip or under the spa lip. This material can be tile, stone, concrete or brick.
- 3) **Preplumb** the spa before it goes into the hole. If there are needs for electrical , bonding or control conduits run them as well before dropping in hole. Connect bond wire to niche would be best.
- 4) **Spa should sit on level 3 ½” thick reinforced concrete pad. Sweep debris off pad prior to dropping in hole.**
- 5) **Install spa** into the hole on top of concrete pad. Use the Eye bolts provided for crane, forklift etc. rigging. Do not hold onto pipes. Use caution with suction and jet plumbing when lowering into hole. **DO NOT STRESS FITTINGS!** Fill Spa with water and check for leaks prior to backfill.

- 6) **Check site reference** points for proper spa positioning (i.e., squaring to house, garage, etc.).
- 7) **Shim to level spa.** Shim with non-compression able material. Re square to house, or ref. point.
- 8) **Dry pack** with cement the gaps that have been created when shimming spa level.
- 9) **Connect pipes to tees** if spa is preplumb. Installers properly support your new plumbing from stressing spas preplumb fittings. After electrical conduit and bond wire is connected to light niche, water test spa before back filling with sand.  
**NOTE: All Nespa products are water tested prior to leaving factory.**

### **ELECTRICAL:**

- 1) All electrical connections to spa or equipment should comply with the most recent national electrical code (NEC), state and local codes.
- 2) Connect electrical conduit to light niche. This work should be done or reviewed by a licensed electrician.
- 3) To install spa light you will need to include inside the PVC conduit to the light niche a solid #8 coated copper wire. (If you are use brass conduit, internal bond wire is not required.) This bond wire should be pulled with the light cord at the same time. This bond wire needs to be attached to the internal bonding lug of the light niche. An approved encapsulate should be applied to bond wire connection in niche.
- 4) An external #8 copper wire shall be connected to the external bonding lug on the rear of the light niche. This copper wire can then be used for additional bonding requirements (i.e., handrails or any other metallic object within 5' of the spa.

### **PLUMBING:**

- 1) **When plumbing a Nespa it is important to properly size the plumbing. We highly recommend that you follow the pump manufacturer's pipe sizing requirements and Uniform Swimming Pool, Spas & Hot Tub Code 2006 ( USPC 2006). This code book is available at [www.JAPMO.org](http://www.JAPMO.org) or (909) 472 4100.**
- 2) The jet air venturi should be a Hartford loop design adjacent to spa shell and air entry point can be located next to spa or remotely at equipment.
- 3) Fill spa with water and test the system for leaks PRIOR to backfilling with sand.

### **SAND BACK FILL:**

- 1) **With water in spa, back-fill around spa perimeter with dry plaster sand and wet wash with hydraulic attachment to hose. Let set for one hour and hydraulic dry again. Be sure water level in spa is at the highest level. Any questions please call us. ( 888) 479-4677.**
- 2) **If spa is free standing on elevated deck or a structure, it is important to fill spa with water and load area prior to installing coping or perimeter decking. If spa is installed in a vault situation a area drain is needed.**

**NESPA ENTERPRISES INC.**

2800 Richter Ave. Suite E

Oroville, CA 95966

Office: (888) 479-4677 Fax: (530) 534-9915

E-Mail: nespa@pacbell.net www.tiledspas.com

**IN-GROUND**

**INSTALLATION**

\*ALL DIMENSIONS SUBJECT TO 1/4" TOLERANCES\*

SCALE: 1/2" = 1'-0"

DATE: 3/27/02

JOB : STANDARD INSTALL

DW #: SI-1, SI-2

**NOTE:**

Sump pump or gravity drain is required for removing water from vault

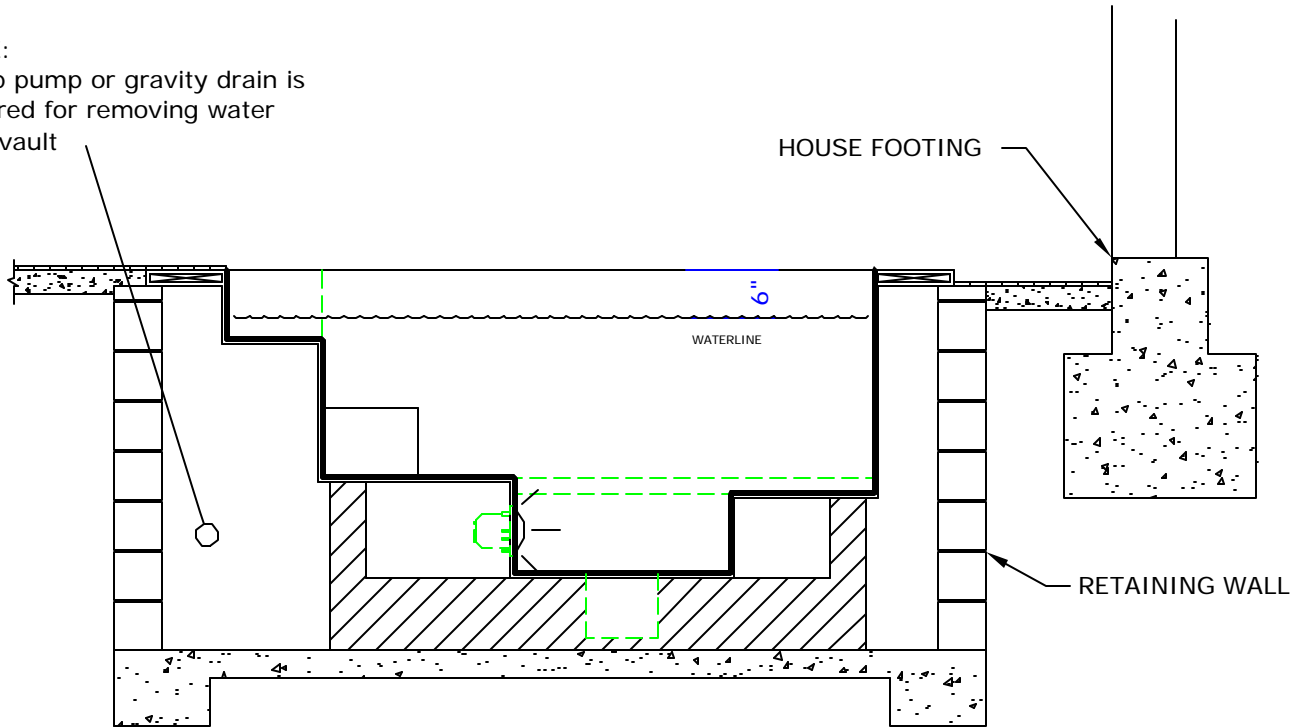

**STANDARD VAULT INSTALLATION**

SI-1

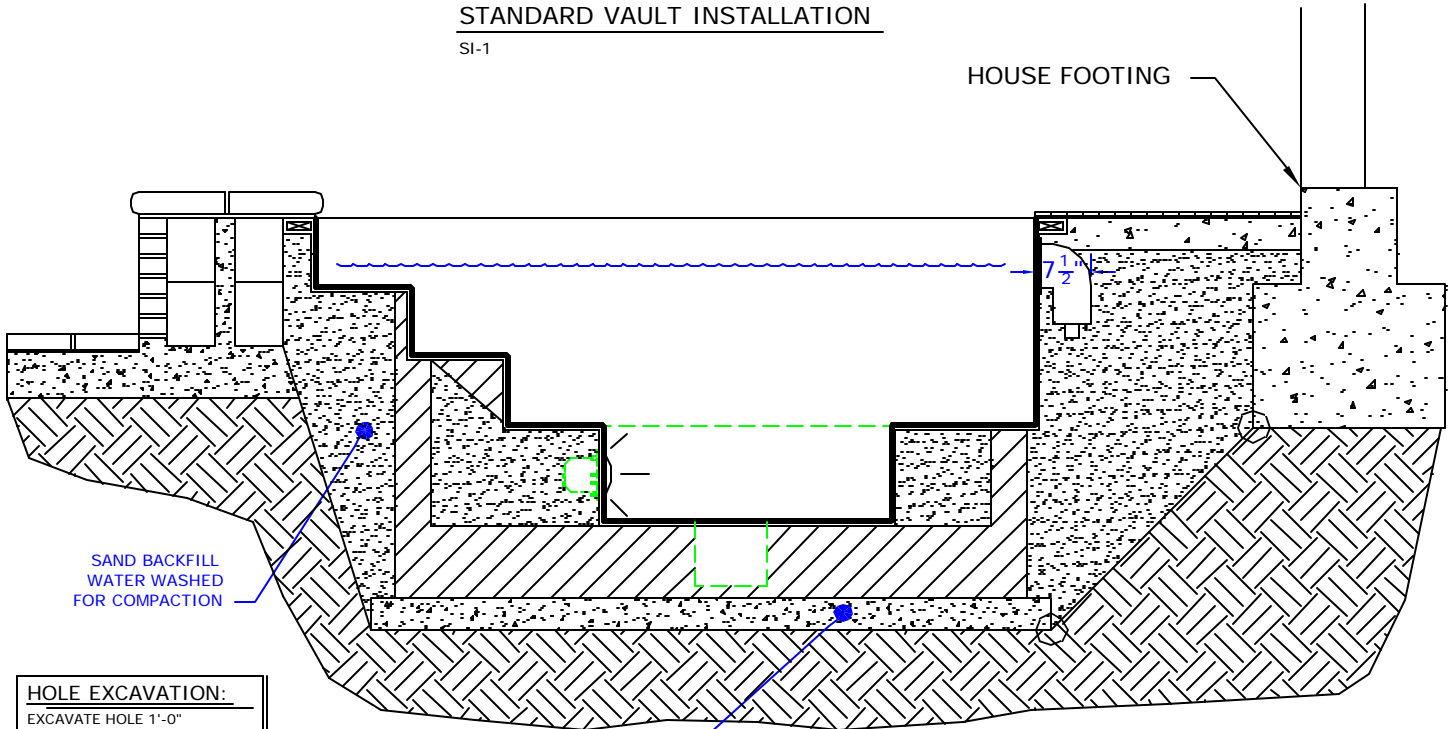

**HOLE EXCAVATION:**

EXCAVATE HOLE 1'-0" LARGER THAN THE OUTSIDE DIAMETER (OD) OF SPA

4" CONCRETE SLAB REINFORCED WITH #10 MESH

**STANDARD INGROUND INSTALLATION**

SI-2

**NOTE:**

Footing can not surcharge spa. Slope from bottom of slab to nearest corner of house footing must not exceed 1" = 1".

# POOL BONDING REQUIREMENTS:

1. THE FOLLOWING PARTS SHALL BE BONDED TOGETHER AND CONNECTED TO THE COMMON BONDING GRID.
  - A. ALL THE METALLIC PARTS OF THE POOL STRUCTURE INCLUDING COPING STONES, DECK, PERMANENT PLAY STRUCTURES, PERMANENT EXERCISE STRUCTURES.
  - B. ALL METAL FITTINGS WITHIN OR ATTACHED TO THE POOL STRUCTURE
  - C. METAL PARTS ASSOCIATED WITH THE POOL WATER CIRCULATING SYSTEM, INCLUDING PUMPS, FILTERS, AND HEATERS.
  - D. METAL PARTS ASSOCIATED WITH POOL COVERS
  - E. METAL SHEATHED CABLES AND RACEWAYS, METAL PIPING AND ALL FIXED METAL PARTS WITHIN 5 FEET HORIZONTALLY OF INSIDE WALLS OF POOL AND WITHIN 12 FEET ABOVE MAXIMUM WATER LEVEL OF POOL.
  - F. METAL PARTS ASSOCIATED WITH OBSERVATION STANDS, TOWERS, PLATFORMS, AND DIVING STRUCTURES.
2. BONDING CONDUCTORS SHALL BE MINIMUM #8 SOLID COPPER, INSULATED E.C. SHALL COORDINATE APPROVED CONNECTOR TYPE AND METHOD WITH LOCAL ELECTRICAL AND/ OR POOL INSPECTOR.
3. SPECIFIC MANUFACTURER'S INSTRUCTIONS REGARDING BONDING OR GROUNDING OF POOL EQUIPMENT, WHETHER INDICATED HEREIN OR NOT, SHALL BE STRICTLY FOLLOWED.
4. THE COMMON BONDING GRID SHALL NOT BE CONNECTED TO ANY ELECTRICAL DISTRIBUTION EQUIPMENT.
5. ANY PARTS IN ADDITION TO THOSE DESCRIBED HEREIN THAT ARE INDICATED BY POOL CONTRACTOR OR LOCAL INSPECTION AUTHORITY SHALL BE BONDED TO THE COMMON BONDING GRID WITH NO ADDITIONAL COSTS INCURRED BY THE OWNER.
6. THE ELECTRICAL CONTRACTOR SHALL COORDINATE BONDING WITH GENERAL CONTRACTOR.

# LIGHT DETAIL

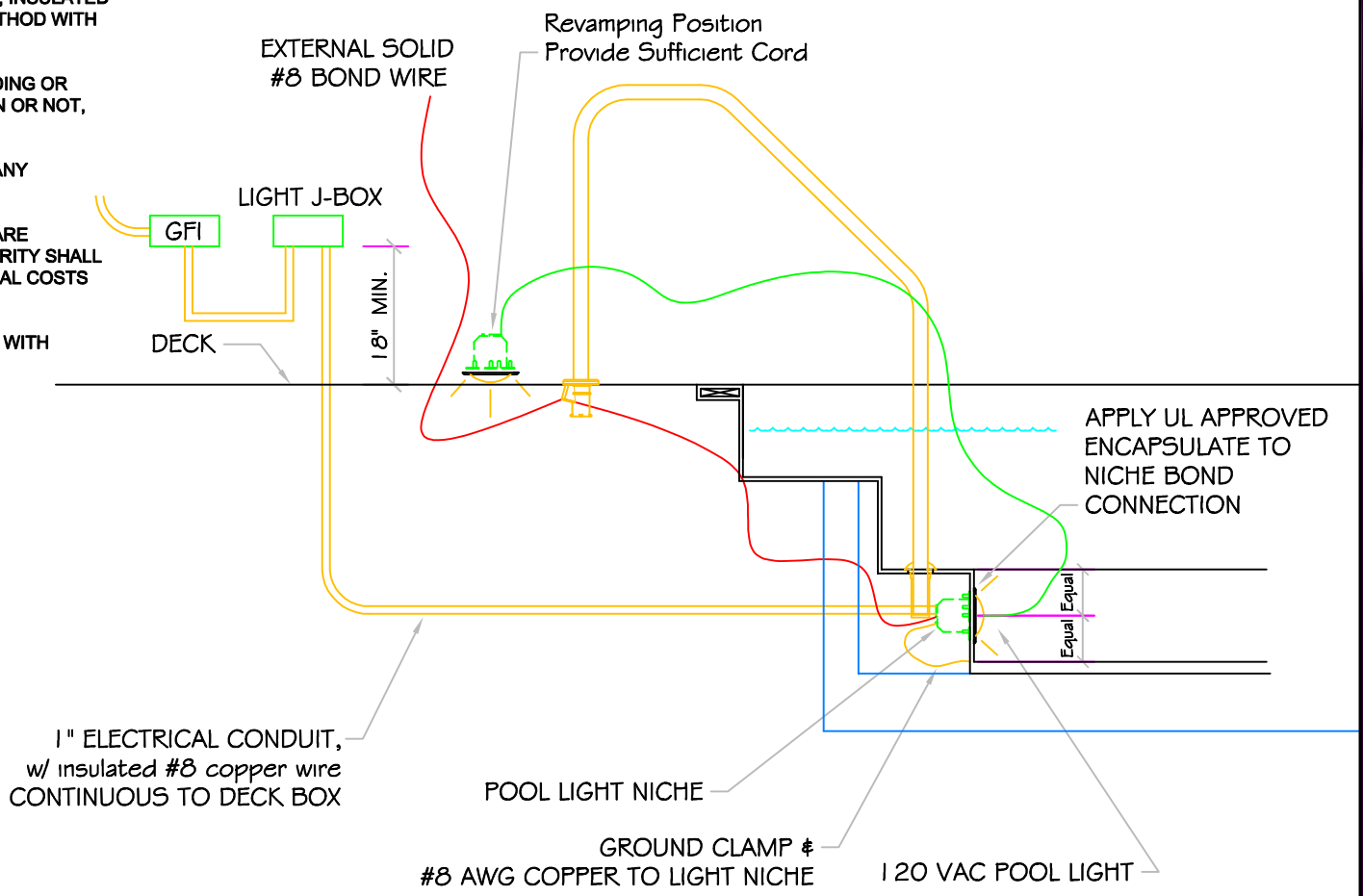

\*ALL DIMENSIONS SUBJECT TO 1/4" TOLERANCES\*

These drawings, concepts, and details contained herein are the original proprietary designs of NESPA ENTERPRISES, developed over many years of experience in the pool and spa industry and as such are protected by the copyright laws of the United States Government. Reproduction of any of the above without written permission to do so by NESPA ENTERPRISES, is illegal.

**NESPA ENTERPRISES INC.**  
 2800 Richter Ave. Ste. C Oroville, CA 95966  
 Office: (530) 534-9910 Fax: (530) 534-9915  
 E-Mail: [sales@tiledspas.com](mailto:sales@tiledspas.com) Web Site: [www.tiledspas.com](http://www.tiledspas.com)



SIZE A	DWG NAME DETAILS	DWG TYPE Detail
SCALE 1/2" = 1'	DATE 7/24/2008	SHEET PAGE 1 OF 1

## **NESPA ENTERPRISES, Inc. LIMITED WARRANTY**

**This LIMITED WARRANTY covering NESPA products is extended to the ORIGINAL PURCHASER-USER BY NESPA ENTERPRISES Inc.(NESPA), 2800 Richter Ave. Unit C California 95966.**

**NESPA products are thoroughly inspected and tested prior to factory shipment. NESPA warrants to the ORIGINAL PURCHASER-USER that NESPA Spas and Swim Spas will be free of defect in workmanship, accessories and parts, provided said accessories and parts were manufactured by NESPA. NESPA, under this LIMITED WARRANTY, warrants only that its Spas and Swim Spas shall be structurally sound, shall retain their shape, and shall retain water for the warranty period. NESPA warrants the adhesion of tile to fiberglass for a period of three (3) years and structural soundness for ten (10) years. NESPA warrants epoxy grout adhesion for a period of three years. If any such defects appear and are reported within the warranty period, NESPA shall repair or replace such defective parts without charge if an inspection proves the claim.**

**The provisions of the LIMITED WARRANTY shall not apply to tile cracked, split, chipped or damaged after the product has left the factory, nor damage to tile caused by freezing nor to damage, defect, malfunction or failure to conform with the above warranty provisions where the damage, defect, malfunction or failure to conform was caused during shipment or by distributor or by unreasonable use by ORIGINAL PURCHASER-USER including improper water balance and improper sand pack or support.**

**This LIMITED WARRANTY shall not apply to any plumbing, equipment, or installation of spas and Swim Spas and shall not apply to any alterations made to or upon NESPA products except alterations made by NESPA employees or NESPA authorized representatives.**

**This LIMITED WARRANTY is expressly in lieu of all other warranties expressed or implied including the warranties of merchantability and fitness for use and all other obligations or liabilities on NESPA'S part, and NESPA neither assumes nor authorizes any other person to assume for NESPA any other liability in connection with the sale of this NESPA product. This LIMITED WARRANTY shall not apply to this NESPA product or any part thereof which has been subject to accident, negligence, alteration, abuse or misuse. NESPA makes no warranty whatsoever with respect to accessories or parts not manufactured by NESPA.**

**The term "ORIGINAL PURCHASER-USER" as used in this LIMITED WARRANTY shall be deemed to mean that person for whom the NESPA product is originally installed.**

**The LIMITED WARRANTY provided herein and the obligations and liabilities of NESPA hereunder are exclusive and are in lieu of, and buyer and original PURCHASE-USER hereby waive all other remedies, warranties, guarantees or liabilities, expressed or implied, arising by law or otherwise (including without limitation and obligations of NESPA with respect to fitness, merchantability, and consequential damages) or whether or not occasioned by NESPA'S negligence.**

**This LIMITED WARRANTY shall not be extended, altered or varied except by a written instrument signed by NESPA and original PURCHASER-USER.**