



NESPA
TILED SPAS

Equipment Booklet

for

Sousou SPA

2800 Richter Ave. Suite C, Oroville, CA 95965 • **voice:** (530)534-9910
fax: (530)534-9915 • **email:** sales@tiledspas.com • **website:** www.tiledspas.com

6/17/2016



Nespa Tiled Spas

Revolution Control Pack

Transforming the Control of Hot Tubs

GFCI

It is required by code to install a Ground Fault Circuit Interrupter (GFCI) in the supply power for a spa. This device will trip the breaker if there is an unsafe electrical condition caused by a malfunctioning component or even the slightest short to ground.

Note: Connect the control system only to a circuit protected by a Class A GFCI mounted at least 5' (1.52M) from the inside walls of the spa/hot tub and in line of sight from the equipment compartment.

Refer to NEC (National Electrical Code), 2005 Edition, Article 680 for more information

WARNING: FAILURE TO PROVIDE A DEDICATED CIRCUIT FOR YOUR SPA ELECTRICAL INSALLATION CAN CAUSE EQUIPMENT DAMAGE AND INVALIDATE YOUR WARRANTY.

Your spa electrical installation must be accomplished by a qualified and licensed electrician in accordance with the National Electrical Code (NEC) Article 680, Canadian Electric Code, and with any local codes effective at the time of installation.

All connections must be made according to the electrical installation label inside the control box. Follow the instructions from the label if they are different than instructions found in this manual. If your electrician is not absolutely sure how to correctly connect your system, call your dealer. Do not guess. Any mistake may be costly and invalidate your equipment warranty.

The GFCI is a mandatory electrical safety device required for all portable spas and hot tubs as specified in the National Electrical Code Article 680-42. The GFCI in your particular installation may be installed at the electrical service panel, a separate sub-panel or built into your Spa's Equipment System. Equipment systems with a built in GFCI meeting the code requirements will be marked on the top of the control panel with an identification label.

Your spa equipment requires a dedicated circuit. No other appliances or lights can be on this circuit. Refer to equipment data label for power supply requirements of your spa equipment. Use copper conductors only.

The ground must be equal to or larger than the largest power conductor.

NOTE: Due to the spa electrical installation requirement of some models, it may be required to SPLIT the incoming electrical service to accommodate the GFCI Circuit Breaker limitations. Contact your electrician if you need additional information on this topic or others related to your spa electrical installation.

Power Requirements for Sousou spa:

1- 60 amp 230v , 4wire, GFCI circuit for primary control pack and 5.5 kw heater.

1- 30 amp 230v, 3 wire, GFCI circuit for secondary heater 5.5 kw heater.



BP501/601

"The Next Generation of Spa Controls"

- Wi-Fi Ready
- New Features in New Enclosure
- The first of a new series of systems
- Press & Hold Buttons for ease of use
- Based on Balboa's most popular model's
- Higher flame retardant and impact resistant materials



Made in the USA
BALBOA
water group

Incomparable System Reliability

The BP501/601 is the first of a new series based on Balboa's most popular models, utilizing advanced technology and higher flame retardent and impact resistant materials. Wi-Fi Enabled with press and hold buttons for ease of use, meet the newly designed BP501/601.

System Specifications

Voltage Supply: (BP501: 120V or 240V) (BP601: 230V)

Sensors: M7 patented temperature probes

Certifications: (BP501: UL recognized) (BP601: NEMKO)

Spa Lights Controls: 1 Amp Max

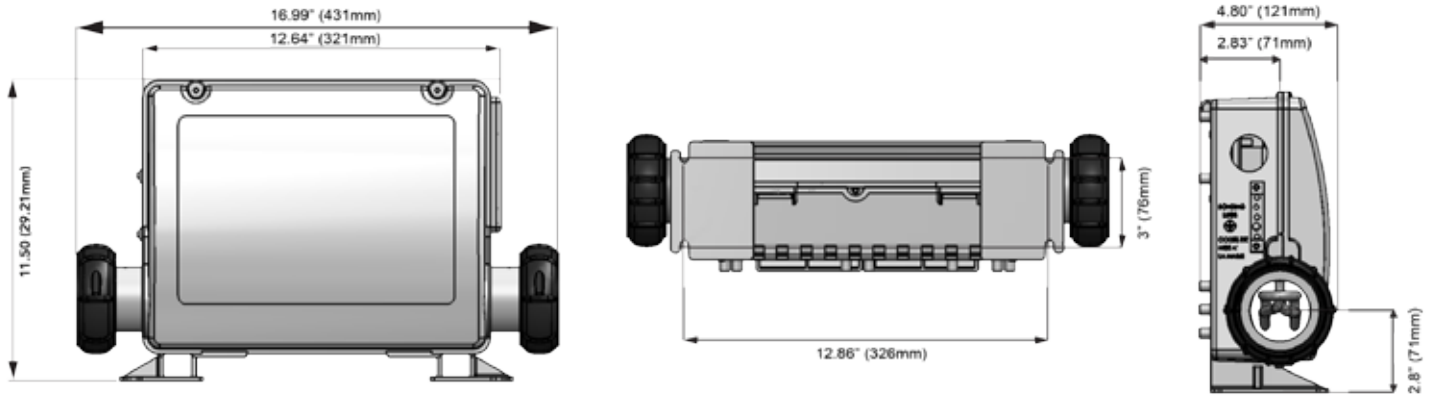

BP501 System Specifications (UL Recognized)

Material No.	Descriptions	Pump 1	Pump 2 or Blower	Pump 3 (Optional with Expander Card)	Heater
56485	SYSTEM BALBOA BP501G1 800INC – 60 Hz	2 spd or 1 spd with Circ	1 spd	NA	5.5 kW 800 Incoloy
56586	SYSTEM BALBOA BP501G1 825INC – 60 Hz	2 spd or 1 spd with Circ	1 spd	NA	5.5 kW 825 Incoloy
56487	SYSTEM BALBOA BP501G1 TITAN – 60 Hz	2 spd or 1 spd with Circ	1 spd	NA	5.5 kW Titanium
56480	SYSTEM BALBOA BP501G2 800INC	2 spd or 1 spd with Circ	1 spd	2 spd	5.5 kW 800 Incoloy
56486	SYSTEM BALBOA BP501G2 825INC	2 spd or 1 spd with Circ	1 spd	2 spd	5.5 kW 825 Incoloy
56482	SYSTEM BALBOA BP501G2 Titanium	2 spd or 1 spd with Circ	1 spd	2 spd	5.5 kW Titanium

BP601 System Specifications - Single Phase (CE Recognized)

Material No.	Descriptions	Pump 1	Pump 2 or Blower	Pump 3 (Optional with Expander Card)	Heater
56497	SYSTEM BALBOA BP601G1 800INC – 50 Hz	2 spd or 1 spd with Circ	1 spd	NA	3.0 kW 800 Incoloy
56498	SYSTEM BALBOA BP601G1 825INC – 50 Hz	2 spd or 1 spd with Circ	1 spd	NA	3.0 kW 825 Incoloy
56499	SYSTEM BALBOA BP601G1 TITAN – 50 Hz	2 spd or 1 spd with Circ	1 spd	NA	3.0 kW Titanium

Note: Refer to tech sheet for optional devices and setups.

Material No.	Descriptions
55911	2" Tailpieces (2-Speed Pump 1). Compatible Plumbing Kits (Coupling nuts and seals included).

BP501/601 Wi-Fi Enabled

Wireless System Control

Now you can control your system wirelessly. With a few simple connections and some additional hardware you can have full control of your spa system. To download the software go to the Apple Apps store and download the free spa app, run through the quick setup and your done.

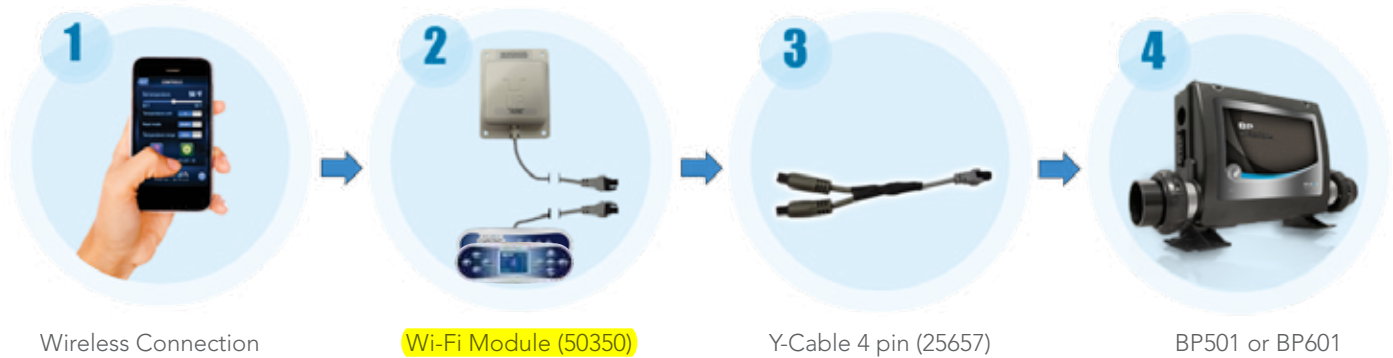

Powerful, Yet Simple Userface

A sleek new topside panel includes a large easy to read back-lit LCD with simple to follow end user menus. With new press and hold button technology, setting temperature and other common tasks have been simplified. User navigation is intuitive and easier than ever, reducing customer service help calls.

BP501/601 Panels And Overlays

Compatible Topside Panels



Panel TP400

- 4 button with LCD display

Material No.:

- 55702: No Overlay (TP400W)
- 55701: No Overlay (TP400T)
- 50259: With Overlay (12510)
- 50260: With Overlay (12511)



Panel TP600

- 6 button with LCD display

Material No.:

- 55676: No Overlay
- 56046: 15ft. Cord
- 50016: For International
- 55673: With Overlay (12101)
- 50014: For Intl' with overlay (12101)



Panel TP800

- 9 button with LCD display

Material No.:

- 50204: No Overlay
- 50261: With Overlay (12512)

Documentation Not Required – New User Friendly Interface

The sleek new topside panel includes a large easy to read backlit LCD with simple to follow end user menus. With new press and hold button technology, setting temperature and other common tasks have been simplified. User navigation is intuitive and easier than ever, reducing customer service help calls.



Overlay 12198 (Jet 1, Jet 2, Flip, Warm, Cool)



Overlay 12511 (Temp, Jets, Light, Aux)



Overlay 12101 (Jets, Aux, Flip, Warm, Cool)



Overlay 12510 (Warm, Cool, Lights, Jets)

Panel TP600

- 56046-01 (TP600 15 ft cable no overlay)
- 56047-01 (TP600 15 ft)
- 50056-01 (TP600 2 Jets with overlay 12198)
- 55673-05 (TP600 with overlay 12101)
- 55676-05 (TP600 no overlay)

Panel TP400

- 55701 (TP400T no overlay)
- 50260 (TP400T with overlay 12511)
- 55702 (TP400W no overlay)
- 50260 (TP400W with overlay 12510)

MANUFACTURED UNDER ONE OR MORE OF THESE PATENTS: U.S. PATENTS: 5332944, 5361215, 5550753, 5559720, 5,883,459, 6253227, 6282370, 6590188, 6976052, 6965815, 7030343, 7,417,834 B2, CANADIAN PATENT: 2342614, AUSTRILIAN PATENT: 2373248 OTHER PATENTS BOTH FOREIGN AND DOMESTIC APPLIED FOR AND PENDING. ALL SOFTWARE COPYRIGHT BALBOA WATER GROUP.

BP501/601_813

©2013 Balboa Water Group. All rights reserved. Your Single Source Solution.
1382 Bell Avenue | Tustin, CA 92780 | p 714.384.0382 | www.balboawatergroup.com

Balboa reserves the right to change technical data without further notice.

BALBOA
water group

TP600 and TP400 Control Panels

User Interface and Programming Reference – Standard Menus

System Model:	BP-Series Systems are BP5XX, BP6XX, BP1XXX, BP2XXX.	
Software Version:	7.0 and later	
Panel Model:	TP600 Series	TP400 Series
Software Version:	2.3 or later	2.4 or later



BALBOA
water group

Manufactured under one or more of these patents. U.S. Patents: 5332944, 5361215, 5550753, 5559720, 5,883,459, 6253227, 6282370, 6590188, 6976052, 6965815, 7030343, 7,417,834 b2, Canadian Patent: 2342614, Australian patent: 2373248 other patents both foreign and domestic applied for and pending. All material copyright of Balboa Water Group.

Main Menus

Navigation

Navigating the entire menu structure is done with 2 or 3 buttons on the control panel.



Some panels have separate **WARM** (Up) and **COOL** (Down) buttons, while others have a single **Temperature** button. In the navigation diagrams Temperature buttons are indicated by a single button icon.

Panels that have two Temperature buttons (Warm and Cool) can use both of them to simplify navigation and programming where a single Temperature icon is shown.

The **LIGHT** Button is also used to choose the various menus and navigate each section.

Typical use of the Temperature button(s) allows changing the Set Temperature while the numbers are flashing in the LCD.

Pressing the **LIGHT** button while the numbers are flashing will enter the menus.

The menu can be exited with certain button presses. Simply waiting for several seconds will return the panel operation to normal.

Key

- Indicates Flashing or Changing Segment
- Indicates Alternating or Progressive Message - every 1/2 second
- ⌵ A temperature button, used for "Action"
- ☀ Light or dedicated "Choose" button, depending on control panel configuration
- Waiting time that keeps the last change to a menu item.
- ***** Waiting time (depends on menu item) that reverts to original setting and ignores any change to that menu item.

Power-up Screens

Each time the System powers up, a series of numbers is displayed. After the startup sequence of numbers, the system will enter Priming Mode (See Page 3).

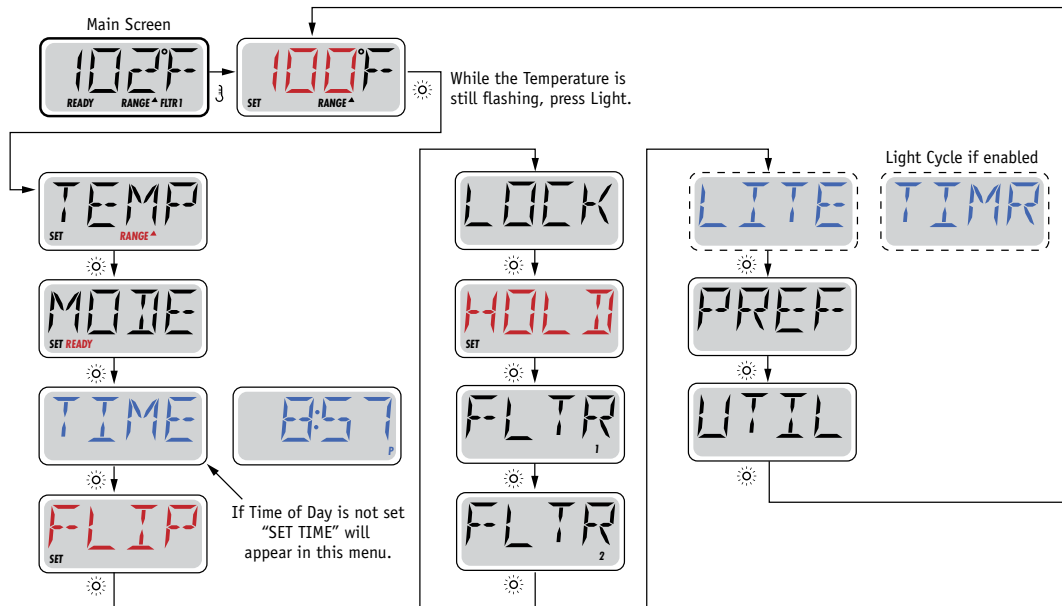

Indicates a Menu Item that Depends on a Manufacturer Configuration and may or may not appear.



Waiting Several Seconds in the Main Menu will allow the display to revert to the Main Screen. Most changes are not saved unless Light ☀ is pressed. Refer to Key above.



Fill it up!

Preparation and Filling

Fill the spa to its correct operating level. Be sure to open all valves and jets in the plumbing system before filling to allow as much air as possible to escape from the plumbing and the control system during the filling process.

After turning the power on at the main power panel, the top-side panel display will go through specific sequences. These sequences are normal and display a variety of information regarding the configuration of the hot tub control.

Priming Mode – M019*

This mode will last for 4-5 minutes or you can manually exit the priming mode after the pump(s) have primed.



Regardless of whether the priming mode ends automatically or you manually exit the priming mode, the system will automatically return to normal heating and filtering at the end of the priming mode. During the priming mode, the heater is disabled to allow the priming process to be completed without the possibility of energizing the heater under low-flow or no-flow conditions. Nothing comes on automatically, but the pump(s) can be energized by pushing the “Jet” buttons. If the spa has a Circ Pump, it can be activated by pressing the “Light” button during Priming Mode.

Priming the Pumps

As soon as the above display appears on the panel, push the “Jet” button once to start Pump 1 in low-speed and then again to switch to high-speed. Also, push the Pump 2 or “Aux” button, if you have a 2nd pump, to turn it on. The pumps will now be running in high-speed to facilitate priming. If the pumps have not primed after 2 minutes, and water is not flowing from the jets in the spa, do not allow the pumps to continue to run. Turn off the pumps and repeat the process. Note: Turning the power off and back on again will initiate a new pump priming session. Sometimes momentarily turning the pump off and on will help it to prime. Do not do this more than 5 times. If the pump(s) will not prime, shut off the power to the spa and call for service.

Important: A pump should not be allowed to run without priming for more than 2 minutes. Under NO circumstances should a pump be allowed to run without priming beyond the end of the 4-5 minute priming mode. Doing so may cause damage to the pump and cause the system to energize the heater and go into an overheat condition.

Exiting Priming Mode

You can manually exit Priming Mode by pressing a “Temp” button (Up or Down). Note that if you do not manually exit the priming mode as described above, the priming mode will be automatically terminated after 4-5 minutes. Be sure that the pump(s) have been primed by this time.

Once the system has exited Priming Mode, the top-side panel will momentarily display the set temperature but the display will not show the temperature yet, as shown below. This is because the system requires approximately 1 minute of water

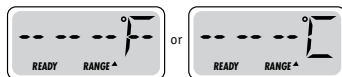

flowing through the heater to determine the water temperature and display it.

*M019 is a Message Code. See Page 15.

Spa Behavior

Pumps

Press the “Jets 1” button once to turn pump 1 on or off, and to shift between low- and high-speeds if equipped. If left running, the pump will turn off after a time-out period. The pump 1 low-speed will time out after 30 minutes. The high-speed will time out after 15 minutes.

On non-circ systems, the low-speed of pump 1 runs when the blower or any other pump is on. If the spa is in Ready Mode (See page 6), Pump 1 low may also activate for at least 1 minute every 30 minutes to detect the spa temperature (polling) and then to heat to the set temperature if needed. When the low-speed turns on automatically, it cannot be deactivated from the panel, however the high speed may be started.

Circulation Pump Modes

If the system is equipped with a circ pump, it will be configured to work in one of three different ways:

- 1, The circ pump operates continuously (24 hours) with the exception of turning off for 30 minutes at a time when the water temperature reaches 3°F (1.5°C) above the set temperature (most likely to happen in very hot climates).
- 2, The circ pump stays on continuously, regardless of water temperature.
- 3, A programmable circ pump will come on when the system is checking temperature (polling), during filter cycles, during freeze conditions, or when another pump is on.

The specific Circulation Mode that is used has been determined by the Manufacturer and cannot be changed in the field.

Filtration and Ozone

On non-circ systems, Pump 1 low and the ozone generator will run during filtration. On circ systems, the ozone will run with the circ pump.

The system is factory-programmed with one filter cycle that will run in the evening (assuming the time-of-day is properly set) when energy rates are often lower. The filter time and duration are programmable. (See page 10)

A second filter cycle can be enabled as needed.

At the start of each filter cycle, the blower (if there is one) or Pump 2 (if there is one) will run briefly to purge its plumbing to maintain good water quality.

Freeze Protection

If the temperature sensors within the heater detect a low enough temperature, then the pump(s) and the blower automatically activate to provide freeze protection. The pump(s) and blower will run either continuously or periodically depending on conditions.

In colder climates, an optional additional freeze sensor may be added to protect against freeze conditions that may not be sensed by the standard sensors. Auxiliary freeze sensor protection acts similarly except with the temperature thresholds determined by the switch. See your dealer for details.

Clean-up Cycle (optional)

When a pump or blower is turned on by a button press, a clean-up cycle begins 30 minutes after the pump or blower is turned off or times out. The pump and the ozone generator will run for 30 minutes or more, depending on the system. On some systems, you can change this setting. (See the Preferences section on page 12)



Temperature and Temp Range

Adjusting the Set Temperature

When using a panel with Up and Down buttons (Temperature buttons), pressing Up or Down will cause the temperature to flash. Pressing a temperature button again will adjust the set temperature in the direction indicated on the button. When the LCD stops flashing, the spa will heat to the new set temperature when required.

If the panel has a single temperature button, pressing the button will cause the temperature to flash. Pressing the button again will cause the temperature to change in one direction (e.g. UP). After allowing the display to stop flashing, pressing the Temperature Button will cause the temperature to flash and the next press will change the temperature in the opposite direction (e.g. DOWN).

Press-and-Hold

If a Temperature button is pressed and held when the temperature is flashing, the temperature will continue to change until the button is released. If only one temperature button is available and the limit of the Temperature Range is reached when the button is being held, the progression will reverse direction.

Dual Temperature Ranges

This system incorporates two temperature range settings with independent set temperatures. The High Range designated in the display by an “up” arrow, and the Low Range designated in the display by a “down” arrow.

These ranges can be used for various reasons, with a common use being a “ready to use” setting vs. a “vacation” setting. The Ranges are chosen using the menu structure below. Each range maintains its own set temperature as programmed by the user. This way, when a range is chosen, the spa will heat to the set temperature associated with that range.

For example:

High Range might be set between 80°F and 104°F.

Low Range might be set between 50°F and 99°F.

More specific Temp Ranges may be determined by the Manufacturer.

Freeze Protection is active in either range.

See Ready and Rest on Page 6

for additional heating control information.

Key

- █ Indicates Flashing or Changing Segment
- █ Indicates Alternating or Progressive Message - every 1/2 second
- ⏏ A temperature button, used for “Action”
- ☀ Light or dedicated “Choose” button, depending on control panel configuration
- Waiting time that keeps the last change to a menu item.
- ***** Waiting time (depends on menu item) that reverts to original setting and ignores any change to that menu item.

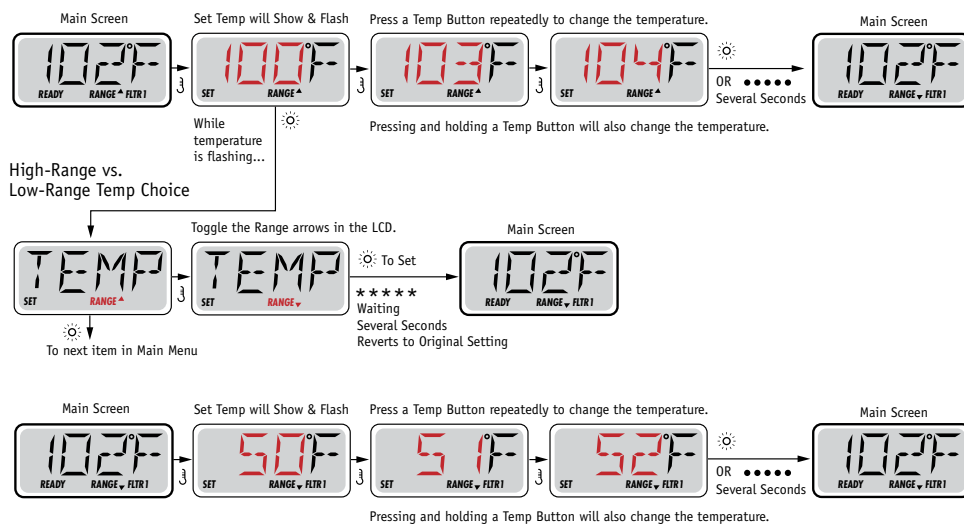

Mode – Ready and Rest

In order for the spa to heat, a pump needs to circulate water through the heater. The pump that performs this function is known as the “heater pump.”

The heater pump can be either a 2-Speed Pump 1 or a circulation pump.

If the heater pump is a 2-Speed Pump 1, READY Mode will circulate water every 1/2 hour, using Pump 1 Low, in order to maintain a constant water temperature, heat as needed, and refresh the temperature display. This is known as “polling.”

REST Mode will only allow heating during programmed filter cycles. Since polling does not occur, the temperature display may not show a current temperature until the heater pump has been running for a minute or two.

Circulation Mode (See Page 4, under Pumps, for other circulation modes)

If the spa is configured for 24HR circulation, the heater pump generally runs continuously. Since the heater pump is always running, the spa will maintain set temperature and heat as needed in Ready Mode, without polling.

In Rest Mode, the spa will only heat to set temperature during programmed filter times, even though the water is being filtered constantly when in Circulation Mode.

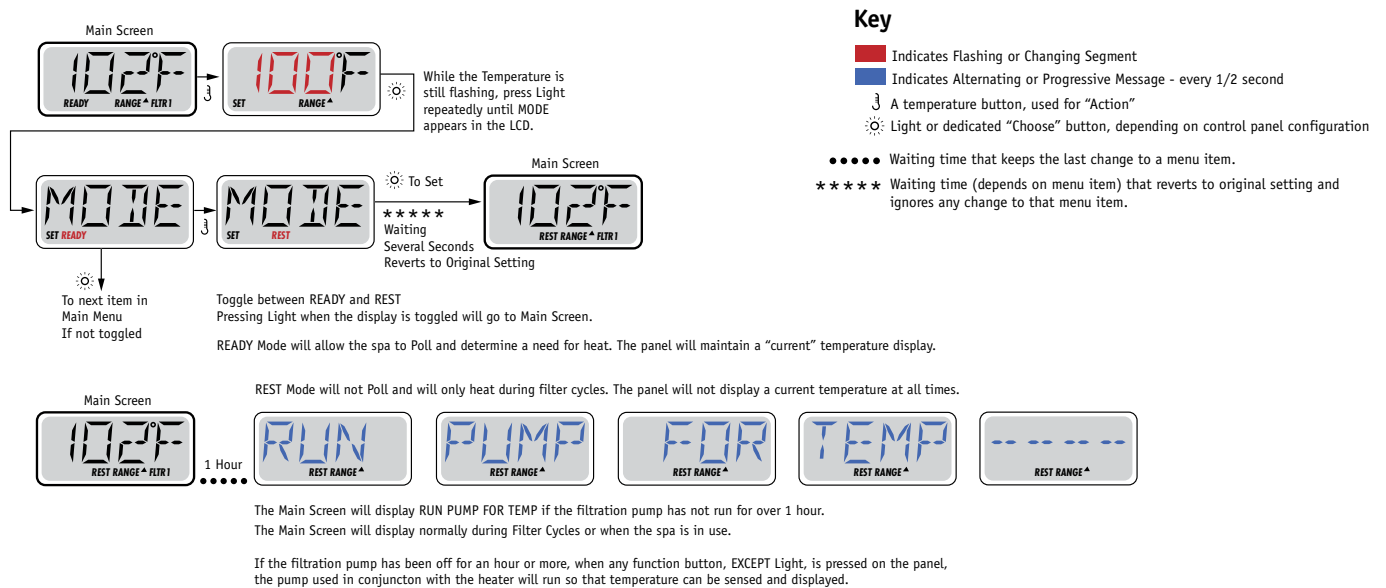

Ready-in-Rest Mode

READY/REST appears in the display if the spa is in Rest Mode and Jet 1 is pressed. It is assumed that the spa is being used and will heat to set temperature. While Pump 1 High can be turned on and off, Pump 1 Low will run until set temperature is reached, or 1 hour has passed. After 1 hour, the System will revert to Rest Mode. This mode can also be reset by entering the Mode Menu and changing the Mode.

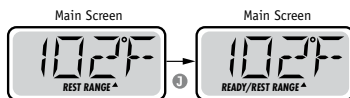

Show and Set Time-of-Day

Be sure to set the Time-of-Day

Setting the time-of-day can be important for determining filtration times and other background features.

When in the TIME menu, SET TIME will flash on the display if no time-of-day is set in the memory.

24-hour time display can be set under the PREF menu. (See Page 10)

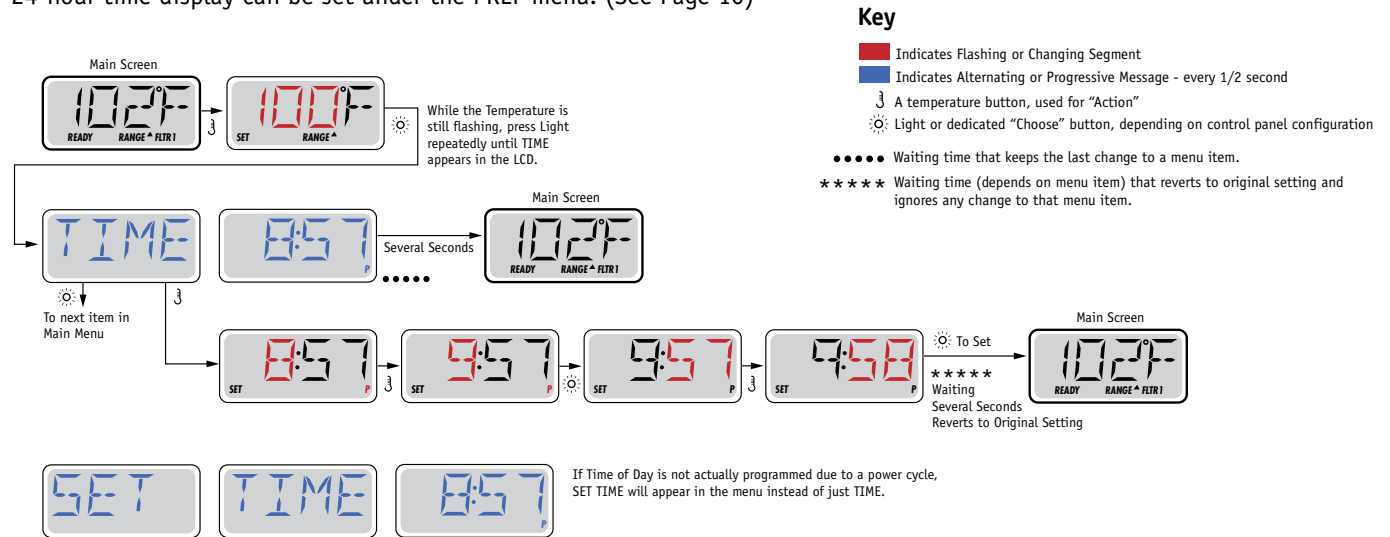

Note:

If power is interrupted to the system, Time-of-Day is not stored. The system will still operate and all other user settings will be stored. If filter cycles are required to run at a particular time of day, resetting the clock will return the filter times to the actual programmed periods.

When the system starts up, it defaults to 12:00 Noon, so another way to get filter times back to normal is to start up the spa at noon on any given day. SET TIME will still flash in the TIME Menu until the time is actually set, but since the spa started at noon, the filter cycles will run as programmed.

Flip (Invert Display)

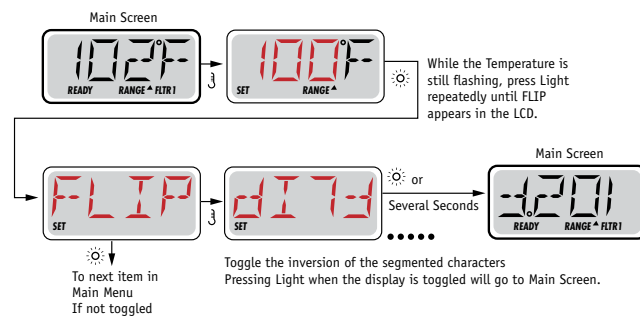

Note:

Some panels may have a dedicated FLIP button, which allows the user to flip the display with a single button-press.



Restricting Operation

The control can be restricted to prevent unwanted use or temperature adjustments.

Locking the panel prevents the controller from being used, but all automatic functions are still active.

Locking the Temperature allows Jets and other features to be used, but the Set Temperature and other programmed settings cannot be adjusted.

Temperature Lock allows access to a reduced selection of menu items.

These include Set Temperature, FLIP, LOCK, UTIL, INFO and FALT LOG.

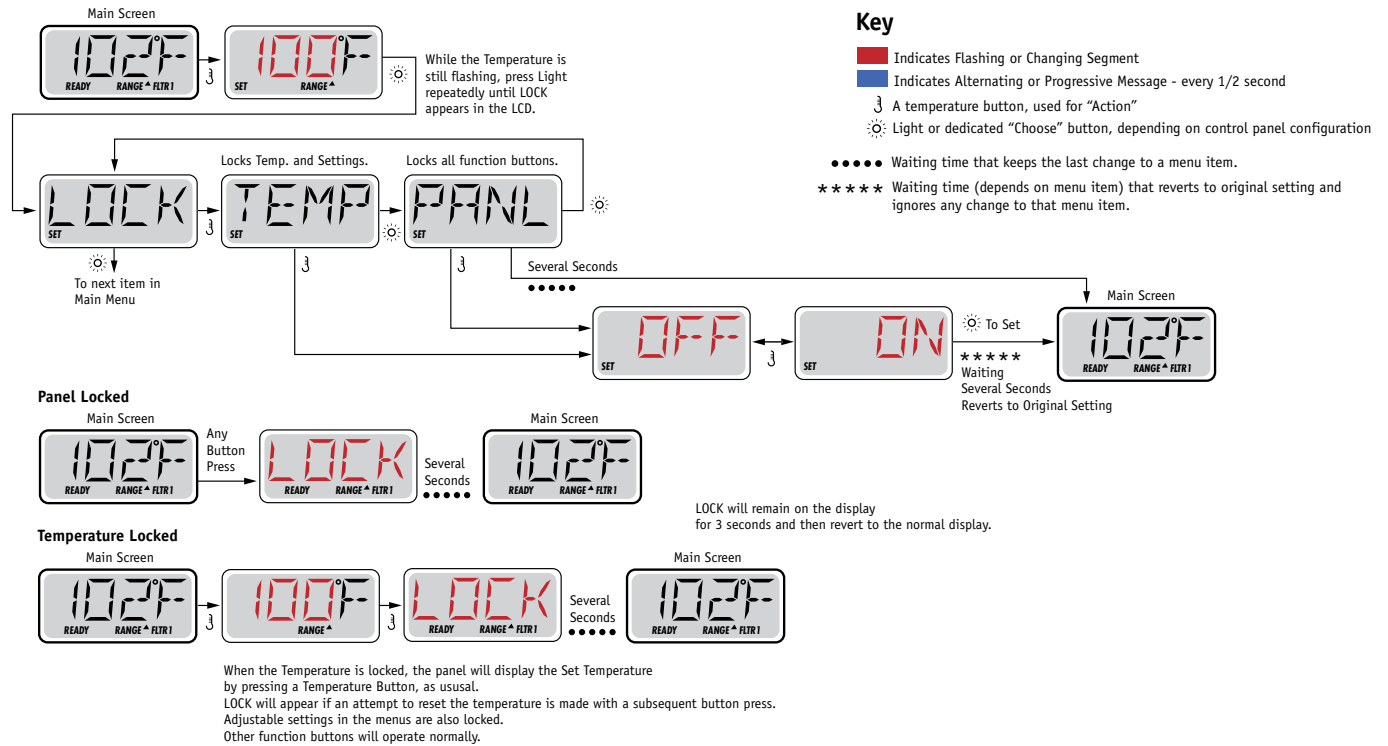

Unlocking

This Unlock sequence may be used from any screen that may be displayed on a restricted panel.

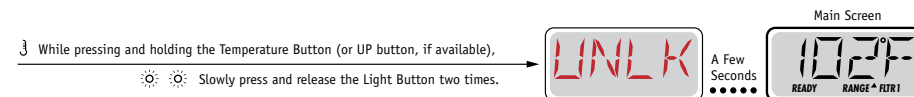

NOTE: If the panel has both an UP and a Down button, the ONLY button that will work in the Unlock Sequence is the UP button.



Hold (Standby)

Hold Mode – M037*

Hold Mode is used to disable the pumps during service functions like cleaning or replacing the filter. Hold Mode will last for 1 hour unless the mode is exited manually.

Drain Mode

Some spas have a special feature that allows a pump to be employed when draining the water. When available, this feature is a component of Hold Mode.

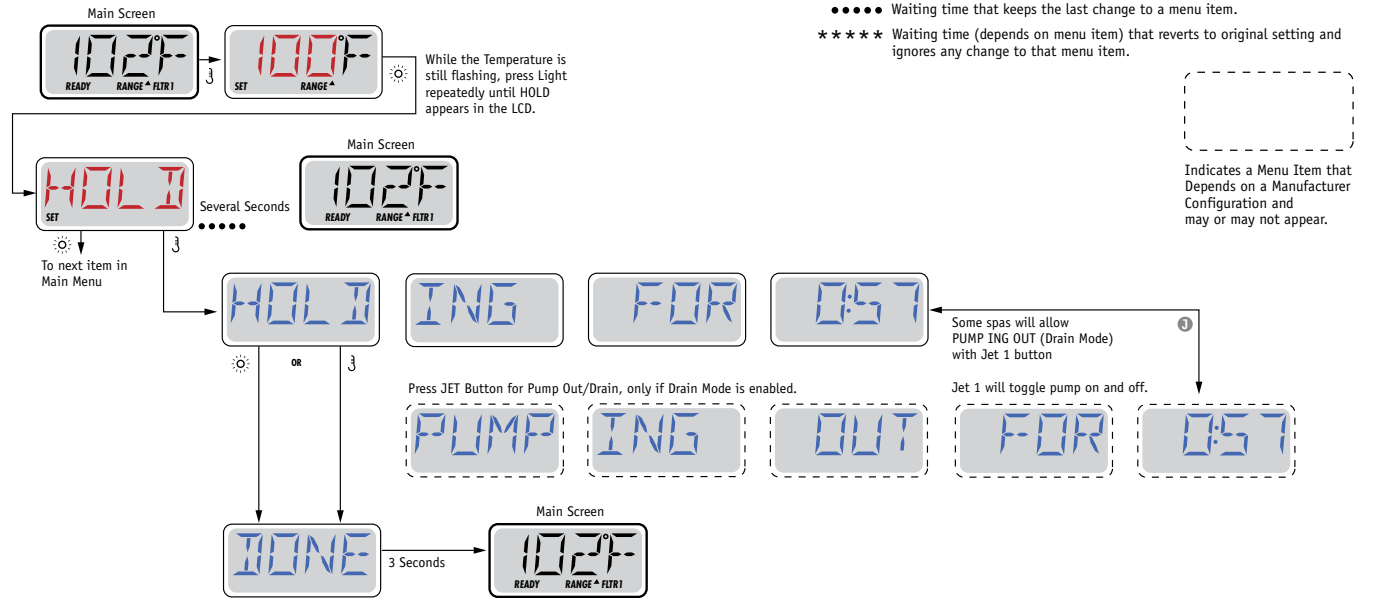

M037 is a Message Code. See Page 15.



Adjusting Filtration

Main Filtration

Filter cycles are set using a start time and a duration. Start time is indicated by an "A" or "P" in the bottom right corner of the display. Duration has no "A" or "P" indication. Each setting can be adjusted in 15-minute increments. The panel calculates the end time and displays it automatically.

Key

- Indicates Flashing or Changing Segment
- Indicates Alternating or Progressive Message - every 1/2 second
- ⌄ A temperature button, used for "Action"
- ☉ Light or dedicated "Choose" button, depending on control panel configuration

- Waiting time that keeps the last change to a menu item.
- ***** Waiting time (depends on menu item) that reverts to original setting and ignores any change to that menu item.

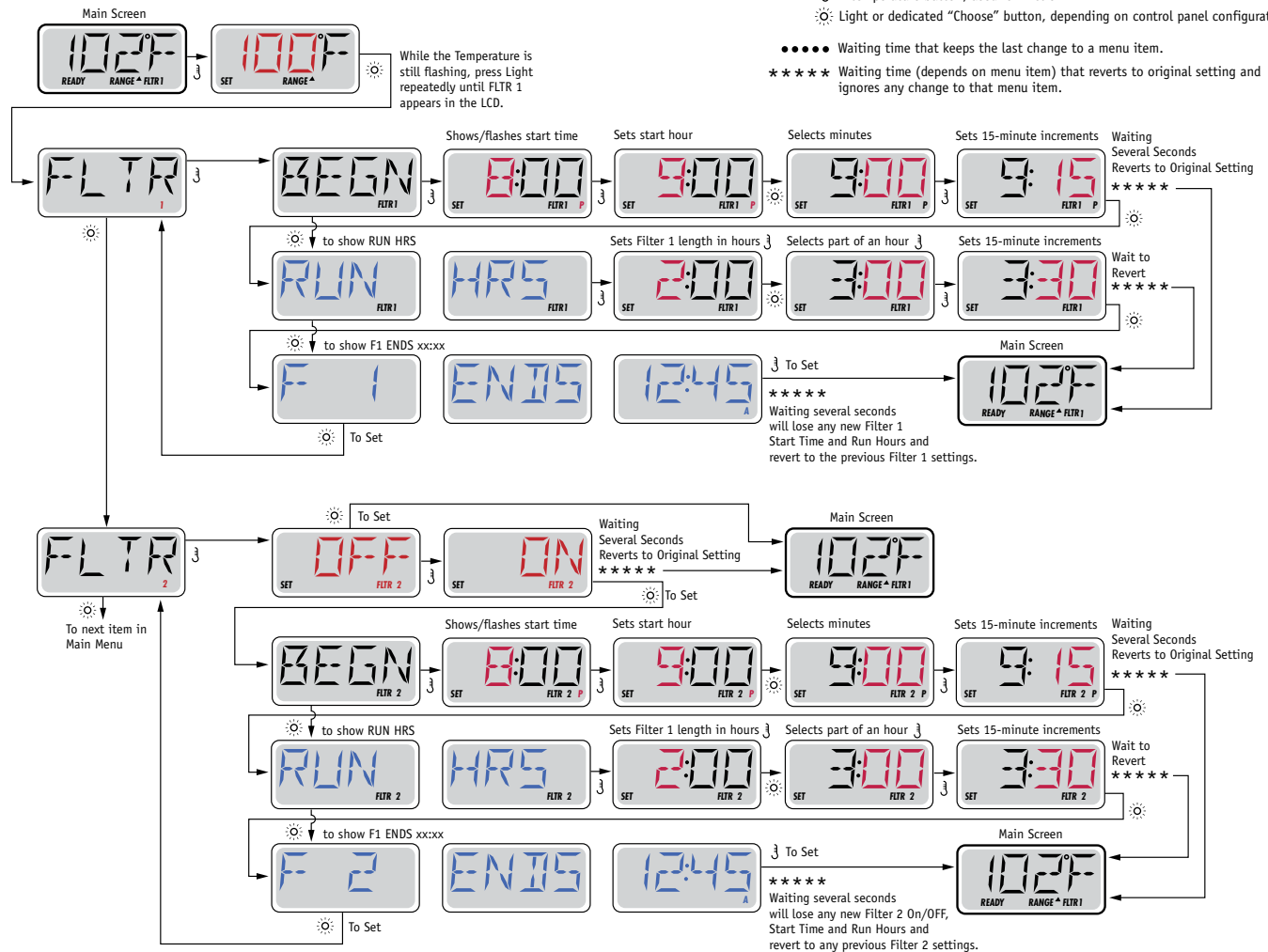

Filter Cycle 2 - Optional Filtration

Filter Cycle 2 is OFF by default.

It is possible to overlap Filter Cycle 1 and Filter Cycle 2, which will shorten overall filtration by the overlap amount.

Purge Cycles

In order to maintain sanitary conditions, secondary Pumps and/or a Blower will purge water from their respective plumbing by running briefly at the beginning of each filter cycle.

If Filter Cycle 1 is set for 24 hours, enabling Filter Cycle 2 will initiate a purge when Filter Cycle 2 is programmed to begin.



Light Timer Programming

Light Timer Option

If LITE TIMR does not appear in the Main Menu, the Light Timer feature is not enabled by the manufacturer.

When available, the Light Timer is OFF by default.

Key

- Indicates Flashing or Changing Segment
- Indicates Alternating or Progressive Message - every 1/2 second
- ⌋ A temperature button, used for "Action"
- ☉ Light or dedicated "Choose" button, depending on control panel configuration
- Waiting time that keeps the last change to a menu item.
- ***** Waiting time (depends on menu item) that reverts to original setting and ignores any change to that menu item.

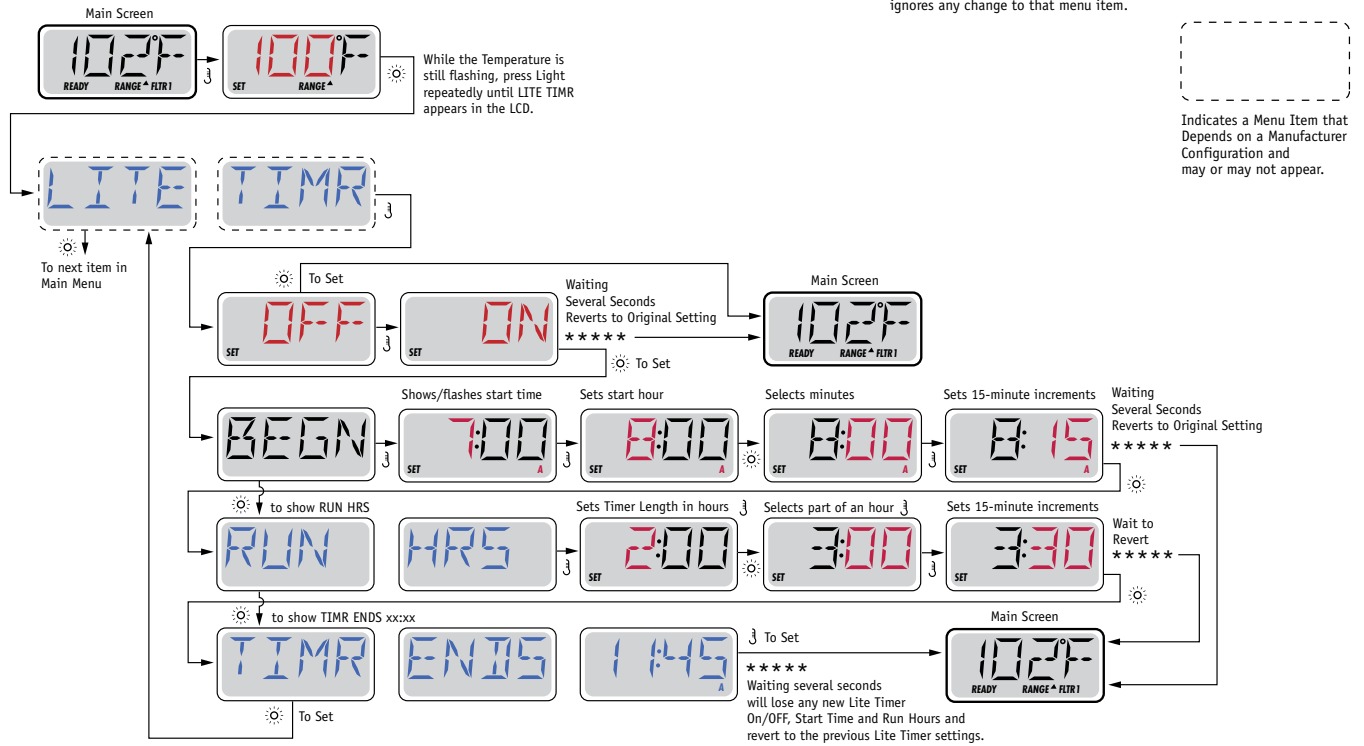

Preferences

F / C (Temp Display)

Change the temperature between Fahrenheit and Celsius.

12 / 24 (Time Display)

Change the clock between 12 hr and 24 hr display.

RE-MIN-DERS (Reminders)

Turn the reminder messages (like "Clean Filter") On or Off.

CLN-UP (Cleanup)

Cleanup Cycle Duration is not always enabled, so it may not appear. When it is available, set the length of time Pump 1 will run after each use. 0-4 hours are available.

DOL-PHIN AD-DRES (Dolphin II and Dolphin III) Applies to RF Dolphin only. (This message may not appear depending on the configuration)

When set to 0, no addressing is used. Use this setting for a Dolphin Remote which is factory set for no address by default. When set between 1 and 7, the number is the address. (See the Dolphin manual for details.)



Preferences

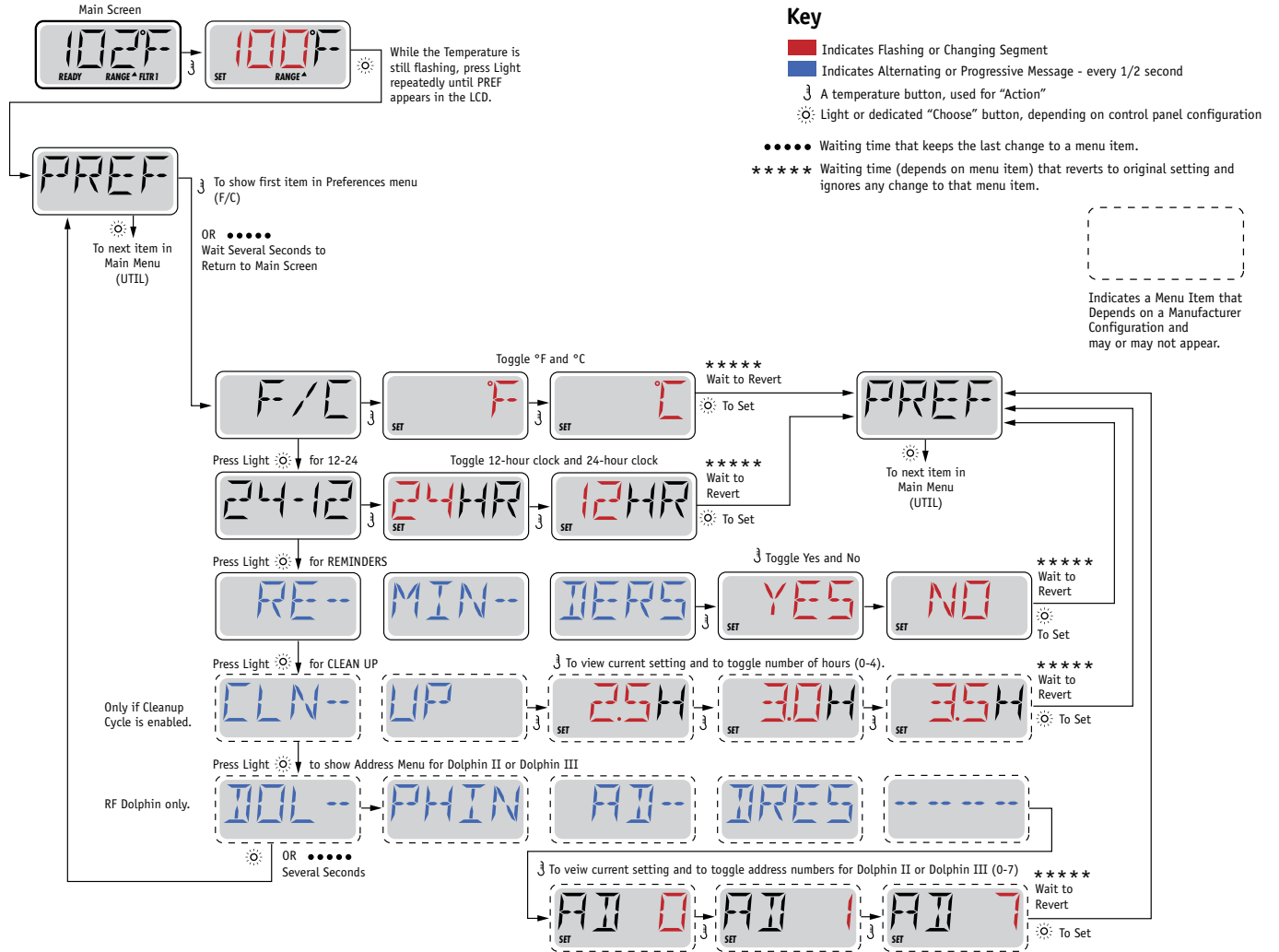

Utilities and Information

INFO (System Information sub-menu)

The System Information Menu displays various settings and identification of the particular system. As each item in the menu is highlighted, the detail for that item is displayed at the bottom of the screen.

SSID (Software ID)

Displays the software ID number for the System.

MODL (System Model)

Displays the Model Number of the System.

SETP (Current Setup)

Displays the currently selected Configuration Setup Number.

SIG (Configuration Signature)

Displays the checksum for the system configuration file.

Heater Voltage (Feature not used on CE rated systems.)

Displays the operating voltage configured for the heater.

Heater Wattage as Configured in Software (CE Systems Only.)

Displays a heater kilowatt rating as programmed into the control system software (1-3 or 3-6).

H _ (Heater Type)

Displays a heater type ID number.

SW _ (Dip Switch Settings)

Displays a number that represents the DIP switch positions of S1 on the main circuit board.

PANL (Panel Version)

Displays a number of the software in the topside control panel.



Additional Utilities

Utilities

In addition to INFO, The Utilities Menu contains the following:

GFCI (GFCI Test) **(Feature not available on CE rated systems.)**

GFCI Test is not always enabled, so it may not appear. This screen allows the GFCI to be tested manually from the panel and can be used to reset the automatic test feature. If the GFCI Test Feature is reset, the device will trip within 7 days. (See Page 17)

A / B (A/B Sensor Temperatures)

When this is set to On, the temperature display will alternate to display temperature from Sensor A and Sensor B in the heater.

FALT LOG (Fault Log)

The Fault Log is a record of the last 24 faults that can be reviewed by a service tech.

DEMO (Demo Mode)

Demo Mode is not always enabled, so it may not appear. This is designed to operate several devices in a sequence in order to demonstrate the various features of a particular hot tub.



Utilities

Key

- Indicates Flashing or Changing Segment
- Indicates Alternating or Progressive Message - every 1/2 second
- ⌋ A temperature button, used for "Action"
- ☉ Light or dedicated "Choose" button, depending on control panel configuration
- Waiting time that keeps the last change to a menu item.
- ***** Waiting time (depends on menu item) that reverts to original setting and ignores any change to that menu item.

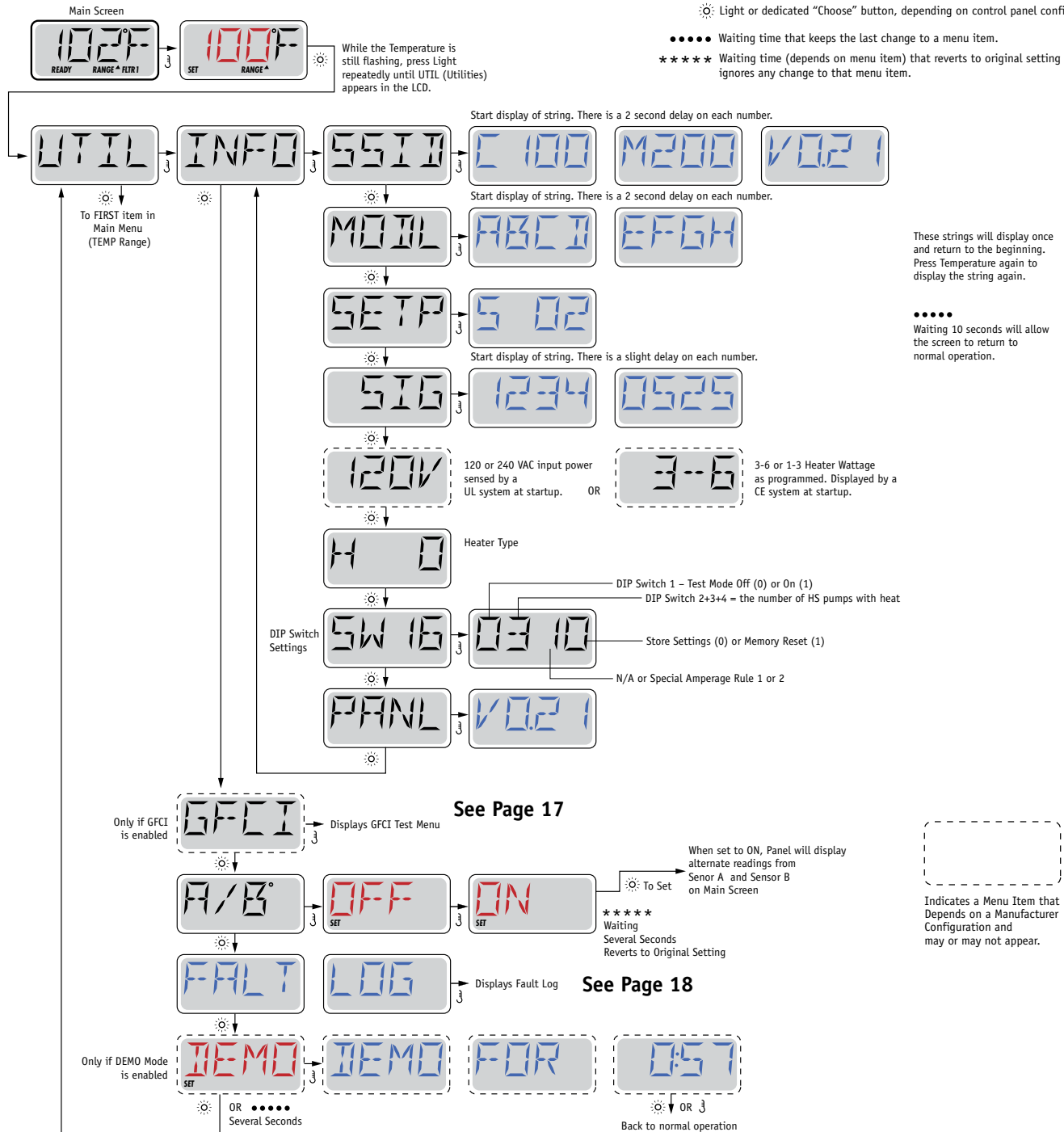

Utilities – GFCI Test Feature

Not Available on CE Rated Systems.

A GFCI is an important safety device and is required equipment on a hot tub installation.

Your spa may be equipped with a GFCI Protection feature. (UL rated systems only.) If your spa has this feature enabled by the manufacturer, the GFCI Trip Test must occur to allow proper spa function.

Within 1 to 7 days after startup, the spa will trip the GFCI to test it. (The number of days is factory programmed.) The GFCI must be reset once it has tripped. After passing the GFCI Trip Test, any subsequent GFCI trips will indicate a ground fault or other unsafe condition and the power to the spa must be shut off until a service person can correct the problem.

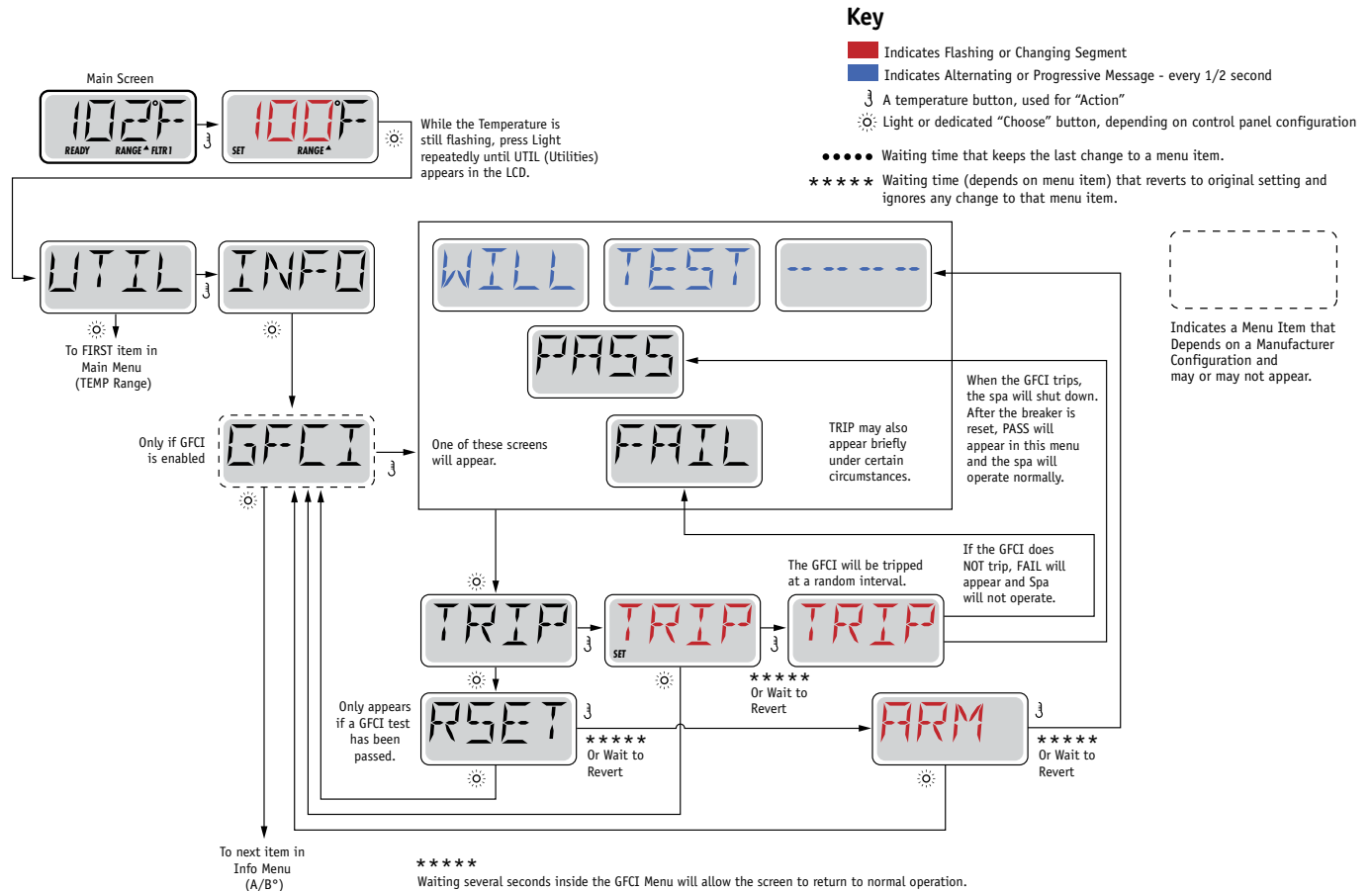

Forcing the GFCI Trip Test

The installer can cause the GFCI Trip Test to occur sooner by initiating it using the above menu.

The GFCI should trip within several seconds and the spa should shut down. If it does not, shut down the power and manually verify that a GFCI breaker is installed and that the circuit and spa are wired correctly. Verify the function of the GFCI with its own test button. Restore power to the spa and repeat the GFCI Trip Test.

Once the GFCI is tripped by the test, reset the GFCI and the spa will operate normally from that point. You can verify a successful test by navigating to the above menu. PASS should appear after a temp button is pressed from the GFCI screen.

The end-user must be trained to expect this one-time test to occur and how to properly reset the GFCI.

Warning:

If freezing conditions exist, a GFCI should be reset immediately or spa damage could result. The end user should always be trained to test and reset the GFCI on a regular basis.



Utilities – Fault Log

A Little History can tell a lot

The Fault Log stores up to 24 events in memory and they can be reviewed under the Fault Log Menu.

Each event captures a Fault Message Code, how many days have passed since the fault, Time of the fault, Set Temperature during the fault, and Sensor A and B temperatures during the fault.

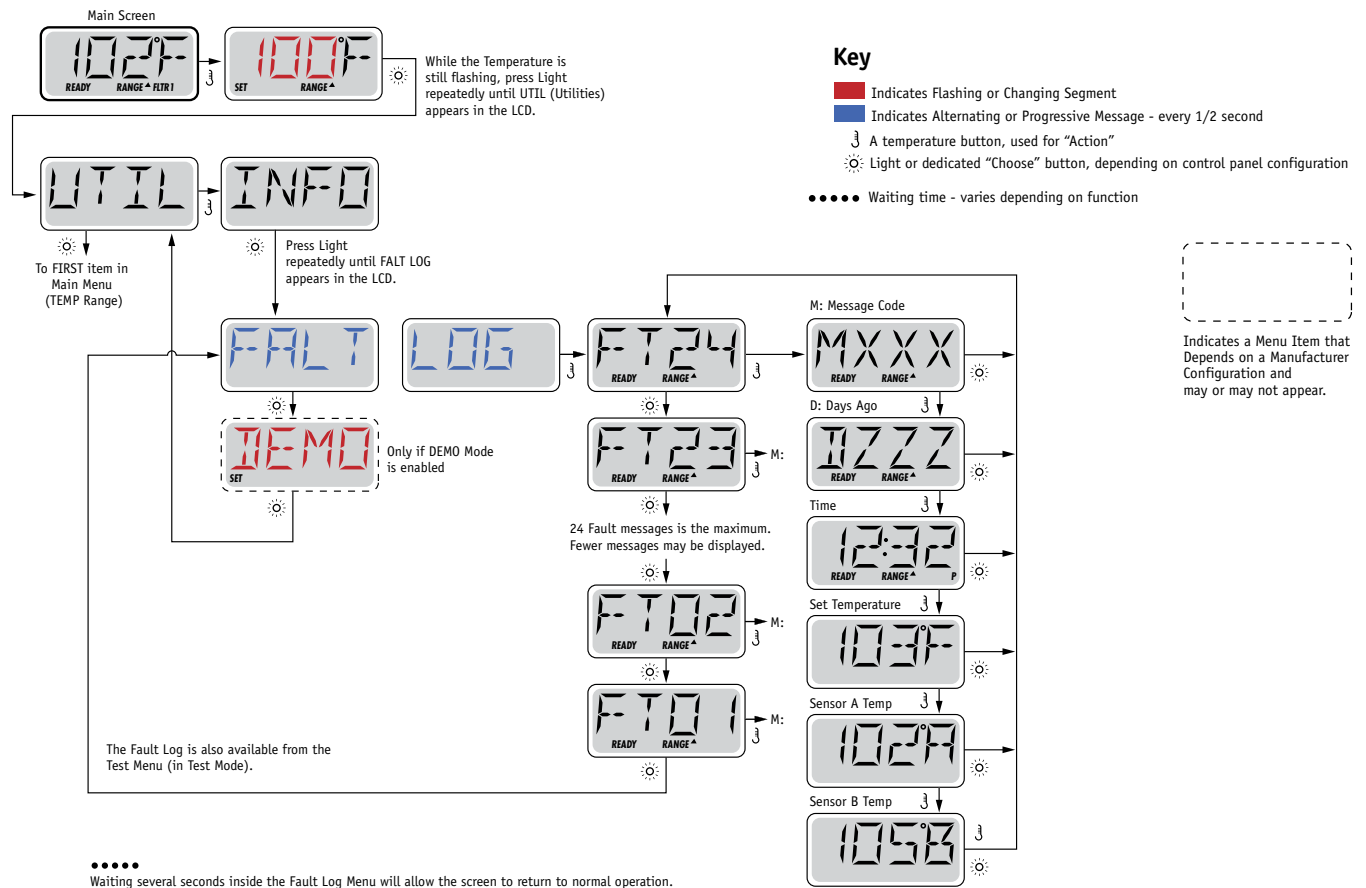

See following pages for various Message Codes and definitions.



General Messages



Priming Mode – M019

Each time the spa is powered up, it will enter Priming Mode. The purpose of Priming Mode is to allow the user to run each pump and manually verify that the pumps are primed (air is purged) and water is flowing. This typically requires observing the output of each pump separately, and is generally not possible in normal operation. Priming Mode lasts 4 minutes, but you can exit it earlier by pressing any Temp button. The heater is not allowed to run during Priming Mode.

NOTE: If your spa has a Circ Pump, it will turn on with Jets 1 in Priming Mode. The Circ Pump will run by itself when Priming Mode is exited.

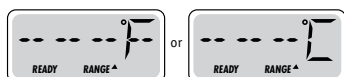

Water Temperature is Unknown

After the pump has been running for 1 minute, the temperature will be displayed.



Too Cold - Freeze Protection

A potential freeze condition has been detected, or the Aux Freeze Switch has closed, and all pumps and blower are activated. All pumps and blower are ON for at least 4 minutes after the potential freeze condition has ended, or when the aux freeze switch opens.

In some cases, pumps may turn on and off and the heater may operate during Freeze Protection.

This is an operational message, not an error indication.



Water is too Hot (OHS) – M029

One of the water temp sensors has detected spa water temp 110°F (43.3°C) and spa functions are disabled. System will auto reset when the spa water temp is below 108°F (42.2°C). Check for extended pump operation or high ambient temp.



Safety Trip - Pump Suction Blockage* – M033

The Safety Trip error message indicates that the vacuum switch has closed. This occurs when there has been a suction problem or a possible entrapment situation avoided. (Note: not all spas have this feature.)

M0XX numbers are Message Codes. See Page 15.

* This message can be reset from the topside panel with any button press.



Heater-Related Messages



Heater Flow is Reduced (HFL) – M016

There may not be enough water flow through the heater to carry the heat away from the heating element. Heater start up will begin again after about 1 min. See “Flow Related Checks” below.



Heater Flow is Reduced (LF)* – M017

There is not enough water flow through the heater to carry the heat away from the heating element and the heater has been disabled. See “Flow Related Checks” below. After the problem has been resolved, you must press any button to reset and begin heater start up.



Heater may be Dry (dr)* – M028

Possible dry heater, or not enough water in the heater to start it. The spa is shut down for 15 min. Press any button to reset the heater start-up. See “Flow Related Checks” below.



Heater is Dry* – M027

There is not enough water in the heater to start it. The spa is shut down. After the problem has been resolved, you must press any button to reset and restart heater start up. See “Flow Related Checks” below.



Heater is too Hot (OHH)* – M030

One of the water temp sensors has detected 118°F (47.8°C) in the heater and the spa is shut down. You must press any button to reset when water is below 108°F (42.2°C). See “Flow Related Checks” below.



A Reset Message may Appear with other Messages.

Some errors may require power to be removed and restored.

Flow-Related Checks

Check for low water level, suction flow restrictions, closed valves, trapped air, too many closed jets and pump prime.

On some systems even when spa is shut down, some equipment may occasionally turn on to continue monitoring temperature or if freeze protection is needed.

* This message can be reset from the topside panel with any button press.



Sensor-Related Messages



Sensor Balance is Poor – M015

The temperature sensors MAY be out of sync by 2°F or 3°F. Call for Service.



Sensor Balance is Poor* – M026

The temperature sensors ARE out of sync. The Sensor Balance is Poor fault has been established for at least 1 hour. Call for Service.



Sensor Failure – Sensor A: M031, Sensor B: M032

A temperature sensor or sensor circuit has failed. Call for Service.

Miscellaneous Messages



No Communications

The control panel is not receiving communication from the System. Call for Service.

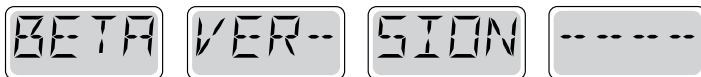

Pre-Production Software

The Control System is operating with test software. Call for Service.



°F or °C is replaced by °T

The Control System is in Test Mode. Call for Service.

* This message can be reset from the topside panel with any button press.



System-Related Messages



Memory Failure - Checksum Error* – M022

At Power-Up, the system has failed the Program Checksum Test. This indicates a problem with the firmware (operation program) and requires a service call.



Memory Warning - Persistent Memory Reset* – M021

Appears after any system setup change. Contact your dealer or service organization if this message appears on more than one power-up, or if it appears after the system has been running normally for a period of time.



Memory Failure - Clock Error* – M020 - Not Applicable on the BP1500

Contact your dealer or service organization.



Configuration Error – Spa will not Start Up

Contact your dealer or service organization.



GFCI Failure - System Could Not Test/Trip the GFCI – M036

NORTH AMERICA ONLY. May indicate an unsafe installation. Contact your dealer or service organization.



A Pump Appears to be Stuck ON – M034

Water may be overheated. POWER DOWN THE SPA. DO NOT ENTER THE WATER. Contact your dealer or service organization.



A Pump Appears to have been Stuck ON when spa was last powered – M035

POWER DOWN THE SPA. DO NOT ENTER THE WATER.
Contact your dealer or service organization.

* This message can be reset from the topside panel with any button press.



Reminder Messages

General maintenance helps.

Reminder Messages can be suppressed by using the PREF Menu. See Page 11.

Reminder Messages can be chosen individually by the Manufacturer. They may be disabled entirely, or there may be a limited number of reminders on a specific model.

The frequency of each reminder (i.e. 7 days) can be specified by the Manufacturer.

Press a Temperature button to reset a displayed reminder message.



Alternates with temperature or normal display.

Appears on a regular schedule, e.g. every 7 days.

Check pH with a test kit and adjust pH with the appropriate chemicals.



Alternates with temperature or normal display.

Appears on a regular schedule, e.g. every 7 days.

Check sanitizer level and other water chemistry with a test kit and adjust with the appropriate chemicals.



Alternates with temperature or normal display.

Appears on a regular schedule, e.g. every 30 days.

Clean the filter media as instructed by the manufacturer. See HOLD on page 6.



Alternates with temperature or normal display.

Appears on a regular schedule, e.g. every 30 days.

The Ground Fault Circuit Interrupter (GFCI) or Residual Current Device (RCD) is an important safety device and must be tested on a regular basis to verify its reliability.

Every user should be trained to safely test the GFCI or RCD associated with the hot tub installation.

A GFCI or RCD will have a TEST and RESET button on it that allows a user to verify proper function.

Warning:

If freezing conditions exist, a GFCI or RCD should be reset immediately or spa damage could result. The end user should always be trained to test and reset the GFCI or RCD on a regular basis.



Reminder Messages Continued

CHNG

WATR

Alternates with temperature or normal display.

Appears on a regular schedule, e.g. every 90 days.

Change the water in the spa on regular basis to maintain proper chemical balance and sanitary conditions.

CLN

COVR

Alternates with temperature or normal display.

Appears on a regular schedule, e.g. every 180 days.

Vinyl covers should be cleaned and conditioned for maximum life.

TRT

WOOD

Alternates with temperature or normal display.

Appears on a regular schedule, e.g. every 180 days.

Wood skirting and furniture should be cleaned and conditioned per the manufacturers instructions for maximum life.

CHNG

FLTR

Alternates with temperature or normal display.

Appears on a regular schedule, e.g. every 365 days.

Filters should be replaced occasionally to maintain proper spa function and sanitary conditions.

CHNG

CART

Alternates with temperature or normal display.

As needed.

Install new mineral cartridge



Warning! Qualified Technician Required for Service and Installation

Basic Installation and Configuration Guidelines

Use minimum 6AWG copper conductors only.

Torque field connections between 21 and 23 in lbs.

Readily accessible disconnecting means to be provided at time of installation.

Permanently connected.

Connect only to a circuit protected by a Class A Ground Fault Circuit Interrupter (GFCI) or Residual Current Device (RCD) mounted at least 5' (1.52M) from the inside walls of the spa/hot tub and in line of sight from the equipment compartment.

CSA enclosure: Type 2

Refer to Wiring Diagram inside the cover of the control enclosure.

Refer to Installation and Safety Instructions provided by the spa manufacturer.

Warning: People with infectious diseases should not use a spa or hot tub.

Warning: To avoid injury, exercise care when entering or exiting the spa or hot tub.

Warning: Do not use a spa or hot tub immediately following strenuous exercise

Warning: Prolonged immersion in a spa or hot tub may be injurious to your health

Warning: Maintain water chemistry in accordance with the Manufacturers instructions.

Warning: The equipment and controls shall be located not less than 1.5 meters horizontally from the spa or hot tub.

Warning! GFCI or RCD Protection.

The Owner should test and reset the GFCI or RCD on a regular basis to verify its function.

Warning! Shock Hazard! No User Serviceable Parts.

Do not attempt service of this control system. Contact your dealer or service organization for assistance. Follow all owner's manual power connection instructions. Installation must be performed by a licensed electrician and all grounding connections must be properly installed.

CSA Compliance/Conformité

Caution:

- Test the ground fault circuit interrupter or residual current device before each use of the spa.
- Read the instruction manual.
- Adequate drainage must be provided if the equipment is to be installed in a pit.
- For use only within an enclosure rated CSA Enclosure 3.
- Connect only to a circuit protected by a Class A ground fault circuit interrupter or residual current device.
- To ensure continued protection against shock hazard, use only identical replacement parts when servicing.

- Install a suitably rated suction guard to match the maximum flow rate marked.

Warning:

- Water temperature in excess of 38°C may be injurious to your health.
- Disconnect the electrical power before servicing.

Attention:

- Toujours vérifier l'efficacité du disjoncteur différentiel avant d'utiliser différentiel avant d'utiliser le bain.
- Lire la notice technique.
- Lorsque l'appareillage est installé dans une fosse, on doit assurer un drainage adéquat.
- Employer uniquement à l'intérieur d'une clôture CSA Enclosure 3.
- Connecter uniquement à un circuit protégé par un disjoncteur différentiel de Class A.
- Afin d'assurer une protection permanente contre le danger de choc électrique, lors de l'entretien employer seulement des pièces de rechange identiques.
- Les prises d'aspiration doivent être équipées de grilles convenant au débit maximal indiqué.

Avertissement:

- Des températures de l'eau supérieures à 38°C peuvent présenter un danger pour la santé.
- Déconnecter du circuit d'alimentation électrique avant l'entretien.

Warning/Advertissement:

- Disconnect the electric power before servicing. Keep access door closed.
- Déconnecter du circuit d'alimentation électrique avant l'entretien. Garder la porte fermée.



SuperFlo[®]

High Performance Pump



Installation and User's Guide

IMPORTANT SAFETY INSTRUCTIONS
READ AND FOLLOW ALL INSTRUCTIONS
SAVE THESE INSTRUCTIONS

Customer Service

If you have questions about ordering Pentair Water Pool and Spa ("Pentair") replacement parts, and pool products, please use the following contact information:

Customer Service (8 A.M. to 5 P.M. — Eastern and Pacific Times)

Phone: (800) 831-7133

Fax: (800) 284-4151

Technical Support

Sanford, North Carolina (8 A.M. to 5 P.M. — Eastern Time)

Phone: (919) 566-8000

Fax: (919) 566-8920

Moorpark, California (8 A.M. to 5 P.M. — Pacific Time)

Phone: (805) 553-5000 (Ext. 5591)

Fax: (805) 553-5515

Web site

visit www.pentairpool.com and staritepool.com to find information about Pentair products



© 2012 Pentair Water Pool and Spa, Inc. All rights reserved.

This document is subject to change without notice.

1620 Hawkins Ave., Sanford, NC 27330 • (919) 566-8000

10951 West Los Angeles Ave., Moorpark, CA 93021 • (805) 553-5000

Trademarks and Disclaimers: SuperFlo®, Pentair Pool Products®, Because reliability matters most®, Sta-Rite®, and Pentair Water Pool and Spa®, are registered trademarks of Pentair Water Pool and Spa, Inc. and/or its affiliated companies in the United States or other countries. Century® is a registered trademark of Regal Beloit EPC, Inc., Franklin Electric® is a registered trademark of Franklin Electric Co., Inc., and AO Smith® is a registered trademark of A.O. Smith, Corp. Unless noted, names and brands of others that may be used in this document are not used to indicate an affiliation or endorsement between the proprietors of these names and brands and Pentair Water Pool and Spa, Inc. Those names and brands may be the trademarks or registered trademarks of those parties or others.

Table of Contents

Important Warning and Safety Instructions.....	ii
Section 1: Introduction.....	1
SuperFlo® Pump Overview.....	1
General Features	2
Section 2: Electrical Requirements.....	3
Wiring Installation.....	3
Section 3: Maintenance	5
Pump Strainer Basket	5
Cleaning the Pump Strainer Basket	5
Winterizing	7
Electric Motor Care	7
Section 4: Servicing	8
Pump Disassembly	8
Pump Reassembly/Seal Replacement	9
Shaft Seal	9
Section 5: Restart Instructions.....	10
Priming the Pump	10
Section 6: Troubleshooting	11
Section 7: Technical Data	12
Illustrated Parts List	12
Pump Curves	13

Pentair Water Pool and Spa®
PUMP WARNING AND SAFETY INSTRUCTIONS
For Pool and Spa Pumps (Non SVRS Pumps)
(Pentair Water Pool and Spa®, Sta-Rite®, and Pentair Pool Products®)

IMPORTANT SAFETY INSTRUCTIONS

When installing and using this electrical equipment, basic safety precautions should always be followed, include the following:

READ AND FOLLOW ALL INSTRUCTIONS



To reduce the risk of injury, do not permit children to use this product.



Risk of Electrical Shock. Connect only to a branch circuit protected by a ground-fault circuit-interrupter (GFCI). Contact a qualified electrician if you cannot verify that the circuit is protected by a GFCI.



This unit must be connected only to a supply circuit that is protected by a ground-fault circuit-interrupter (GFCI). Such a GFCI should be provided by the installer and should be tested on a routine basis. To test the GFCI, push the test button. The GFCI should interrupt power. Push the reset button. Power should be restored. If the GFCI fails to operate in this manner, the GFCI is defective. If the GFCI interrupts power to the pump without the test button being pushed, a ground current is flowing, indicating the possibility of an electric shock. Do not use this pump. Disconnect the pump and have the problem corrected by a qualified service representative before using.



This pump is for use with permanent swimming pools and may also be used with hot tubs and spas if so marked. Do not use with storable pools. A permanently-installed pool is constructed in or on the ground or in a building such that it cannot be readily disassembled for storage. A storable pool is constructed so that it is capable of being readily disassembled for storage and reassembled to its original integrity.

General Warnings

- Never open the inside of the drive motor enclosure. There is a capacitor bank that holds a 230 VAC charge even when there is no power to the unit.
- The pump is not submersible.
- The pump is capable of high flow rates; use caution when installing and programming to limit pumps performance potential with old or questionable equipment.
- Code requirements for the electrical connection differ from state to state. Install equipment in accordance with the National Electrical Code and all applicable local codes and ordinances.
- Before servicing the pump; press the Stop button and disconnect the communication cable, then switch OFF power to the pump by disconnecting the main circuit to the pump.
- This appliance is not intended for use by persons (including children) of reduced physical, sensory or mental capabilities, or lack of experience and knowledge, unless they have been given supervision or instruction concerning the use of the appliance by a person responsible for their safety.
- To reduce the risk of injury, do not permit children to use this product.

SAVE THESE INSTRUCTIONS

Pentair Water Pool and Spa®
PUMP WARNING AND SAFETY INSTRUCTIONS
For Pool and Spa Pumps (Non SVRS Pumps)
(Pentair Water Pool and Spa®, Sta-Rite®, and Pentair Pool Products®)

Warnings and safety instructions for Pentair Water Pool and Spa® pumps and other related products are available at: <http://www.pentairpool.com/pool-owner/safety-warnings/> or call (800) 831-7133 for additional free copies of these instructions.

Please refer to <http://www.pentairpool.com/pool-owner/safety-warnings/> for warning and safety instructions related to the SuperFlo® High Performance Pump.

READ AND FOLLOW ALL WARNING AND SAFETY INSTRUCTIONS



This is the safety alert symbol. When you see this symbol on your system or in this manual, look for one of the following signal words and be alert to the potential for personal injury.



Warns about hazards that can cause death, serious personal injury, or major property damage if ignored.



Warns about hazards that may cause death, serious personal injury, or major property damage if ignored.



Warns about hazards that may or can cause minor personal injury or property damage if ignored.

NOTE indicates special instructions not related to hazards.

Carefully read and follow all safety instructions in this manual and on equipment. Keep safety labels in good condition; replace if missing or damaged.



FAILURE TO FOLLOW ALL INSTRUCTIONS AND WARNINGS CAN RESULT IN SERIOUS BODILY INJURY OR DEATH. THIS PUMP SHOULD BE INSTALLED AND SERVICED ONLY BY A QUALIFIED POOL SERVICE PROFESSIONAL. INSTALLERS, POOL OPERATORS AND OWNERS MUST READ THESE WARNINGS AND ALL INSTRUCTIONS IN THE OWNER'S MANUAL BEFORE USING THIS PUMP. THESE WARNINGS AND THE OWNER'S MANUAL MUST BE LEFT WITH THE POOL OWNER.



SUCTION ENTRAPMENT HAZARD: STAY OFF THE MAIN DRAIN AND AWAY FROM ALL SUCTION OUTLETS!



THIS PUMP PRODUCES HIGH LEVELS OF SUCTION AND CREATES A STRONG VACUUM AT THE MAIN DRAIN AT THE BOTTOM OF YOUR POOL AND SPA. THIS SUCTION IS SO STRONG THAT IT CAN TRAP ADULTS OR CHILDREN UNDER WATER IF THEY COME IN CLOSE PROXIMITY TO A POOL OR SPA DRAIN OR A LOOSE OR BROKEN DRAIN COVER OR GRATE.

READ AND KEEP THESE INSTRUCTIONS FOR FUTURE REFERENCE

Pentair Water Pool and Spa®
PUMP WARNING AND SAFETY INSTRUCTIONS
For Pool and Spa Pumps (Non SVRS Pumps)
(Pentair Water Pool and Spa®, Sta-Rite®, and Pentair Pool Products®)

THE USE OF UNAPPROVED COVERS OR ALLOWING USE OF THE POOL OR SPA WHEN COVERS ARE MISSING, CRACKED OR BROKEN CAN RESULT IN BODY OR LIMB ENTRAPMENT, HAIR ENTANGLEMENT, BODY ENTRAPMENT, EVISCERATION AND/OR DEATH.

The suction at a pool or spa drain or outlet can cause:

Limb Entrapment: When a limb is sucked or inserted into an opening resulting in a mechanical bind or swelling. This hazard is present when a drain cover is missing, broken, loose, cracked or not properly secured.

Hair Entanglement: When the hair tangles or knots in the drain cover, trapping the swimmer underwater. This hazard is present when the flow rating of the cover is too small for the pump or pumps.

Body Entrapment: When a portion of the body is held against the drain cover trapping the swimmer underwater. This hazard is present when the drain cover is missing, broken or the cover flow rating is not high enough for the pump or pumps.

Evisceration/Disembowelment: When a person sits on an open pool (particularly a child wading pool) or spa outlet and suction is applied directly to the intestines, causing severe intestinal damage. This hazard is present when the drain cover is missing, loose, cracked, or not properly secured.

Mechanical Entrapment: When jewelry, swimsuit, hair decorations, finger, toe or knuckle is caught in an opening of an outlet or drain cover. This hazard is present when the drain cover is missing, broken, loose, cracked, or not properly secured.

NOTE: ALL SUCTION PLUMBING MUST BE INSTALLED IN ACCORDANCE WITH THE LATEST NATIONAL AND LOCAL CODES FOR SWIMMING POOLS, SPAS AND HOT TUBS, INCLUDING NSPI STANDARDS AND CPSC GUIDELINES.

⚠ WARNING

TO MINIMIZE THE RISK OF INJURY DUE TO SUCTION ENTRAPMENT HAZARD:

- Pools and spas should utilize a minimum of two drains per pump.
- A properly installed and secured ANSI/ASME A112.19.8 approved anti-entrapment suction cover must be used for each drain.
- Each suction cover must be installed at least three (3') feet apart, as measured from the nearest point to nearest point.
- Regularly inspect all covers for cracks, damage and advanced weathering.
- If a cover becomes loose, cracked, damaged, broken or is missing, close the pool or spa immediately, shut off the pump, post a notice and keep the pool or spa closed until an appropriate certified cover is properly installed.
- Replace drain covers as necessary. Drain covers deteriorate over time due to exposure to sunlight, pool chemicals and weather.
- Avoid getting hair, limbs or body in close proximity to any suction cover, pool drain or outlet.
- Disable suction outlets or reconfigure into return inlets.

⚠ WARNING

A clearly labeled emergency shut-off switch for the pool pump and spa jet pump must be in an easily accessible, obvious place near the pool or spa. Make sure bathers know where it is and how to use it in case of emergency.

Pentair Water Pool and Spa® PUMP WARNING AND SAFETY INSTRUCTIONS For Pool and Spa Pumps (Non SVRS Pumps) (Pentair Water Pool and Spa®, Sta-Rite®, and Pentair Pool Products®)

The Virginia Graeme Baker (VGB) Pool and Spa Safety Act creates new requirements for owners and operators of commercial swimming pools and spas.

Commercial pools or spas constructed on or after December 19, 2008, shall utilize:

- (A) A multiple main drain system without isolation capability with suction outlet covers that meet ASME/ANSI A112.19.8a Suction Fittings for Use in Swimming Pools, Wading Pools, Spas, and Hot Tubs and either:
 - (i) A safety vacuum release system (SVRS) meeting ASME/ANSI A112.19.17 Manufactured Safety Vacuum Release systems (SVRS) for Residential and Commercial Swimming Pool, Spa, Hot Tub, and Wading Pool Suction Systems and/or ASTM F2387 Standard Specification for Manufactured Safety Vacuum Release Systems (SVRS) for Swimming pools, Spas and Hot Tubs or
 - (ii) A properly designed and tested suction-limiting vent system or
 - (iii) An automatic pump shut-off system.

Commercial pools and spas constructed prior to December 19, 2008, with a single submerged suction outlet shall use a suction outlet cover that meets ASME/ANSI A112.19.8a and either:

- (A) A SVRS meeting ASME/ANSI A112.19.17 and/or ASTM F2387, or
- (B) A properly designed and tested suction-limiting vent system, or
- (C) An automatic pump shut-off system, or
- (D) Disabled submerged outlets, or
- (E) Suction outlets shall be reconfigured into return inlets.

For Installation of Electrical Controls at Equipment Pad (ON/OFF Switches, Timers and Automation Load Center)



Install all electrical controls at equipment pad, such as on/off switches, timers, and control systems, etc. to allow the operation (startup, shut-down, or servicing) of any pump or filter so the user does not place any portion of his/her body over or near the pump strainer lid, filter lid or valve closures. This installation should allow the user enough space to stand clear of the filter and pump during system start-up, shut down or servicing of the system filter.



HAZARDOUS PRESSURE: STAND CLEAR OF PUMP AND FILTER DURING START-UP

Pool and spa circulation systems operate under high pressure. When any part of the circulating system (i.e. locking ring, pump, filter, valves, etc.) is serviced, air can enter the system and become pressurized. Pressurized air can cause the pump housing cover filter lid and valves to violently separate which can result in severe personal injury or death. Filter tank lid and strainer cover must be properly secured to prevent violent separation. Stand clear of all circulation system equipment when turning on or starting up pump.

Before servicing pool and spa equipment, make note of the filter pressure. Be sure that all controls are set to ensure the system cannot inadvertently start during service. Turn off all power to the pump.

IMPORTANT: Place filter manual air relief valve in the open position and wait for all pressure in the system to be relieved.

Before starting the system, fully open the manual air relief valve and place all system valves in the “open” position to allow water to flow freely from the pool and spa back to the pool or spa. Stand clear of all pool and spa equipment and start the pump.

IMPORTANT: Do not close filter manual air relief valve until all pressure has been discharged from the valve and a steady stream of water appears. Observe filter pressure gauge and be sure it is not higher than the pre-service condition.

Pentair Water Pool and Spa®
PUMP WARNING AND SAFETY INSTRUCTIONS
For Pool and Spa Pumps (Non SVRS Pumps)
(Pentair Water Pool and Spa®, Sta-Rite®, and Pentair Pool Products®)

General Installation Information

- All work must be performed by a qualified pool professional, and must conform to all national, state, and local codes.
- Install to provide drainage of compartment for electrical components.
- These instructions contain information for a variety of pump models and therefore some instructions may not apply to a specific model. All models are intended for use in swimming pool applications. The pump will function correctly only if it is properly sized to the specific application and properly installed.

⚠ WARNING

Pumps improperly sized or installed or used in applications other than for which the pump was intended can result in severe personal injury or death. These risks may include but not be limited to electric shock, fire, flooding, suction entrapment or severe injury or property damage caused by a structural failure of the pump or other system component.

⚠ WARNING

The pump can produce high levels of suction within the suction side of the plumbing system. These high levels of suction can pose a risk if a person comes within the close proximity of the suction openings. A person can be seriously injured by this high level of vacuum or may become trapped and drown. It is absolutely critical that the suction plumbing be installed in accordance with the latest national and local codes for swimming pools.

SAVE THESE INSTRUCTIONS

Section 1

Introduction

SuperFlo® High Performance Pump Overview

The perfect choice for all types of pools, the SuperFlo® was specifically designed to be your best choice for a variety of inground pools. Thick walled body parts, a heavy duty 56 square flange motor, and highly engineered hydraulics make this rugged and tested design perfect for any pool, spa, water feature, or fountain. And SuperFlo's silent running capability and small footprint allow it to easily drop into a compact equipment pad.

Efficient, Quiet, Rugged, and Versatile

All pumps from Pentair Water Pool and Spa incorporate innovative hydraulic engineering that has been refined for over 40 years. SuperFlo® reflects the latest and best Pentair technology, to move water more efficiently for lower operational costs. Compact, rugged, and easy to maintain, SuperFlo® will deliver years of reliable service.



SuperFlo® Pump

General Features

- Extremely quiet operation
- Unionized fittings (1.5" and 2") for simple replacement
- Cam and Ramp™ lid for easy cleaning and maintenance
- Heavy-duty, high service factor 56 square flange motor for long life
- Integral volute and pot reduce hydraulic noise
- See-through lid permits easy inspection of strainer basket

Additional Features:

- 115 volt or 230 volt models available
- 1/2 Hp to 2 1/2 Hp configurations to accommodate a wide range of applications
- Self-priming for quick, easy start-up
- Every SuperFlo pump is performance and pressure tested prior to shipment to ensure superior quality
- UL/CUL/NSF

Section 2

Electrical Requirements

This section describes how to wire the SuperFlo® pump.

Note: Before installing this product, read and follow all warning notices and instructions on pages ii-vi.

Electrical Requirements and Wiring



WARNING — Risk of electrical shock or electrocution.



This pool pump must be installed by a licensed or certified electrician or a qualified pool serviceman in accordance with the National Electrical Code and all applicable local codes and ordinances. Improper installation will create an electrical hazard which could result in death or serious injury to pool users, installers, or others due to electrical shock, and may also cause damage to property.

Always disconnect power to the pool pump at the circuit breaker before servicing the pump. Failure to do so could result in death or serious injury to serviceman, pool users or others due to electric shock.

Wiring Installation

1. Be sure all electrical breakers and switches are turned off before wiring motor.
2. Be sure that the wiring voltage matches the motor voltage (230 VAC or 115 VAC). If they do not match, the motor can overheat.
3. Choose a wire size from the Chart 1. When in doubt use a heavier gauge (larger diameter) wire. Heavier gauge will allow the motor to run cooler and more efficient.
4. Be sure all electrical connections are clean and tight.
5. Cut wires to the appropriate length so they do not overlap or touch when connected to the terminal board.

Chart 1.

SUPPLY WIRE SIZES (AWG)						
(Size and Length by Horsepower)						
Hp	115 volts			230 volts		
	50 ft.	100 ft.	150 ft.	50 ft.	100 ft.	150 ft.
1/3	14	14	12	14	14	14
1/2	14	12	10	14	14	14
3/4	12	12	10	14	14	14
1	12	10	8	14	14	14
1½	10	10	8	14	14	12
2	10	8	8	14	12	12
2½	-	-	-	12	12	10
3	-	-	-	12	12	10

Wiring Installation, (Continued).

6. Permanently ground the motor using the green ground terminal located on the inside of the motor canopy or access plate, see **Figure 1**. Use the correct wire size and type specified by National Electrical Code. Make sure the ground wire is connected to an electrical service ground.
7. Bond the motor to the pool structure in accordance with the National Electrical Code. UL requires use of a solid copper bonding conductor not smaller than 8 AWG.
8. Connect the wire from the accessible wire connector on the motor to all metal parts of the swimming pool, spa, or hot tub structure and to all electrical equipment, metal conduit, and metal piping within 5 feet of the inside walls of the swimming pool, spa, or hot tub. For Canada, a 6 AWG or larger solid copper bonding conductor is required.
9. The pump should be permanently connected to either a circuit breaker, 2-pole timer or 2-pole relay. If AC power is supplied by a GFCI circuit breaker, use a dedicated circuit breaker that has no other electrical loads.
10. Connect the pump permanently to a circuit. Make sure no other lights or appliances are on the same circuit.

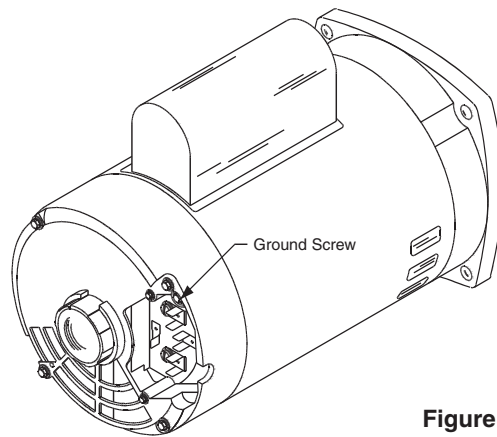

Figure 1.

Section 3

Maintenance

This section describes how to maintain the SuperFlo® pump.

The Pump Strainer Basket

This unit, sometimes referred to as the ‘Hair and Lint Pot’, is the unit in front of the volute. Inside the chamber is the basket which must be kept clean of leaves and debris at all times. View basket through the ‘See Through Lid’ to inspect for leaves and debris.

Regardless of the length of time between filter cleaning, it is most important to visually inspect the hair and lint pot basket at least once a week. A clogged basket reduces the efficiency of the filter and heater and puts added stress on the pump motor.

Cleaning the Pump Strainer Basket

⚠ WARNING — **DO NOT** open the strainer pot if pump fails to prime or if pump has been operating without water in the strainer pot. Pumps operated in these circumstances may experience a build up of vapor pressure and may contain scalding hot water. Opening the pump may cause serious personal injury. In order to avoid the possibility of personal injury, make sure the suction and discharge valves are open and strainer pot temperature is cool to touch, then open with extreme caution.

⚠ CAUTION — To prevent damage to the pump and filter and for proper operation of the system, clean pump strainer and skimmer baskets regularly.

1. Turn off motor.
2. Relieve pressure in the system.
3. Turn the clamp and lid in a counter-clockwise direction until it stops.
4. Turn the clamp and lid set to remove the clamp and lid.
5. Put the debris from the basket into the trash and rinse the basket. Replace the basket if cracked.
6. Replace the basket. Be sure to align the slot in the basket with the rib in the volute, see [Figure 2](#).
7. Fill the pump pot and volute up to the inlet port with water.
8. Clean the cover, cover O-ring, and sealing surface of the pump pot. Grease the O-ring with a silicone based lubricant.

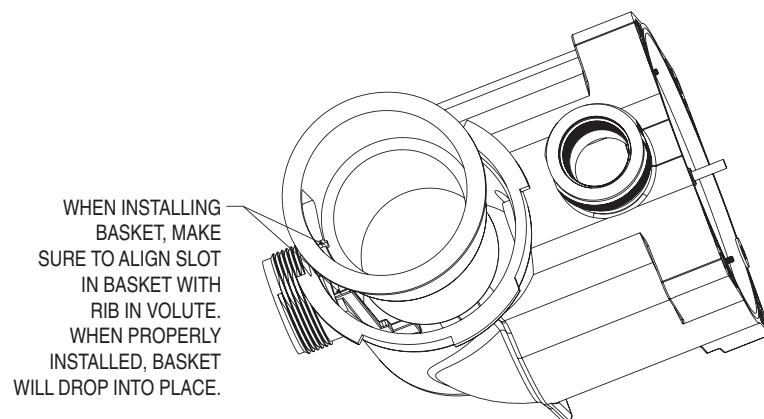

Figure 2.

Cleaning the Pump Strainer Basket, (Continued).

9. Reinstall the lid by placing the clamp and the lid on the pot; see [Figure 3](#).
10. Be sure the lid O-ring is properly placed. Seat the clamp and lid then turn clockwise until the handles are horizontal; see [Figure 4](#).

⚠ WARNING — THIS FILTER OPERATES UNDER HIGH PRESSURE.



When any part of the circulating system (e.g., Lock Ring, Pump, Filter, Valves, etc.) is serviced, air can enter the system and become pressurized. Pressurized air can cause the lid to separate which can result in severe injury, death, or property damage. To avoid this potential hazard, follow these instructions.

11. Turn the power “ON” at the house circuit breaker. Reset the pool time clock to the correct time
12. Open the manual air relief valve on top of the filter.
13. Stand clear of the filter. Start the pump.
14. Bleed air from the filter until a steady stream of water comes out. Close the manual air relief valve.

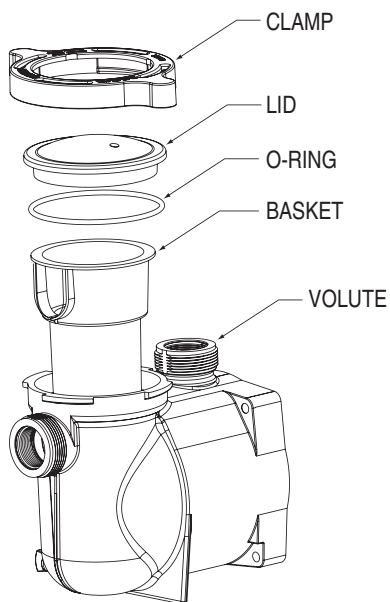

Figure 3.

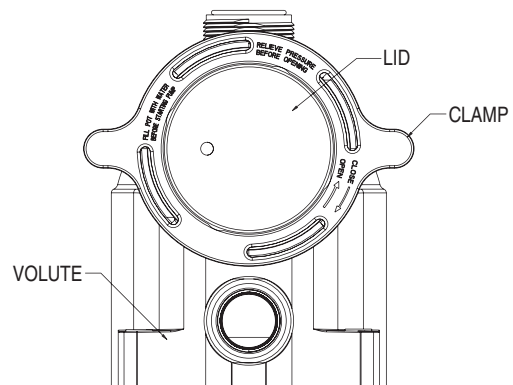

Figure 4.

Winterizing

1. If the air temperature drops below 35° F., the water in the pump can freeze and cause damage. Freeze damage is not warrantable.
2. To prevent freeze damage follow the procedures listed below:
 - Shut off electrical power for the pump at the house circuit breaker.
 - Drain the water out of the pump case by removing the two thumb-twist drain plugs from the case. Store the plugs in the pump basket.
 - Cover the motor to protect it from severe rain, snow and ice.
 - Do not wrap the motor in plastic. It will cause condensation and rust on the inside of the motor.



CAUTION — In mild climate area, when temporary freezing conditions may occur, run your filtering equipment all night to prevent freezing.

Care of Electric Motor

1. Protect from heat.
 - Shade the motor from the sun.
 - Any enclosure must be well ventilated to prevent overheating.
 - Provide ample cross ventilation.
2. Protect against dirt.
 - Protect from any foreign matter or splashing water.
 - Do not store (or spill) pool chemicals near the motor.
 - Avoid sweeping or stirring up dust near the motor while in operation.
 - If a motor has been damaged by dirt it voids the motor warranty.
3. Protect against moisture.
 - Protect from splashing pool water and lawn sprinklers.
 - Protect from the weather.
 - If a motor has become wet - let it dry before operating. Do not allow the pump to operate if it has been flooded.
 - If a motor has been damaged by water it voids the motor warranty.

NOTE

- **DO NOT** wrap motor with plastic or other air tight materials. The motor may be covered during a storm, for winter storage, etc., but never when operating, or expecting operation.
 - When replacing the motor, be certain that the motor support is correctly positioned to support the size of motor being installed.
-

Section 4

Servicing

This section describes how to service the SuperFlo® pump.

WARNING — Risk of electrical shock or electrocution.



This pool pump must be installed by a licensed or certified electrician or a qualified pool serviceman in accordance with the National Electrical Code and all applicable local codes and ordinances. Improper installation will create an electrical hazard which could result in death or serious injury to pool users, installers, or others due to electrical shock, and may also cause damage to property.

Always disconnect power to the pool pump at the circuit breaker before servicing the pump. Failure to do so could result in death or serious injury to serviceman, pool users or others due to electric shock.

Read all servicing instructions before working on the pump.

WARNING — **DO NOT** open the strainer pot if pump fails to prime or if pump has been operating without water in the strainer pot. Pumps operated in these circumstances may experience a build up of vapor pressure and may contain scalding hot water. Opening the pump may cause serious personal injury. In order to avoid the possibility of personal injury, make sure the suction and discharge valves are open and strainer pot temperature is cool to touch, then open with extreme caution.



CAUTION — Be sure not to scratch or mar the polished shaft seal faces; seal will leak if faces are damaged.

Pump Disassembly

1. All moving parts are located in the rear sub-assembly of this pump.

Required Tools:

- 1/4 inch socket or open end wrench.
 - 3/8 inch socket or open end wrench.
 - 9/16 inch open end wrench.
 - Flat blade screwdriver.
2. To remove and repair the motor sub-assembly perform the following procedures:
 - a. Turn off the pump circuit breaker at the main panel.
 - b. Drain the pump by removing the drain plugs.
 - c. Remove the 4 bolts that hold the main pump body (strainer pot/volute) to the rear sub-assembly.
 - d. GENTLY pull the two pump halves apart, removing the rear sub-assembly.
 - e. Remove the three hex head screws holding the diffuser in position.
 - f. Hold the impeller securely in place and remove the impeller lock screw by using a flat blade screwdriver or wrench. The screw is a left-handed thread and loosens in a clockwise direction.
 - g. Remove the shaft cap located at the back of the motor and hold the shaft secure with a 1/2 inch (Century® motors) or 7/16 inch (Franklin Electric® Motors) open-end wrench. On AO Smith® motors, remove the motor canopy, move the capacitor to one side and hold the shaft with a 7/16 inch open-end wrench.
 - h. To unscrew the impeller from the shaft, twist the impeller counter-clockwise.
 - i. Remove the four bolts from the seal plate to the motor using a 3/8 inch wrench.
 - j. Place the seal plate face down on a flat surface and tap out the ceramic seal.
 - k. Clean the seal plate, seal housing, and the motor shaft.

Pump Reassembly/Seal Replacement

1. When installing the replacement seal into the seal plate, use soapy water to wet the rubber boot before pressing it into the seal plate.
2. Remount the seal plate to the motor.
3. Before installing the rotating portion of the seal on the motor shaft, wet the motor shaft with soapy water and slide the seal onto the motor shaft. Ensure that the carbon face contacts the ceramic face of the stationary seat. Press the seal into the seal plate with your thumbs and wipe off the ceramic with a clean cloth.
4. Grease the motor shaft thread and screw impeller onto the motor shaft.
5. Screw in the impeller lock screw (counter-clockwise to tighten).
6. Remount the diffuser onto the seal plate. Make sure the plastic pins and holding screw inserts are aligned.
7. Grease the diffuser quad ring and seal plate O-ring prior to reassembly.
8. Grease the bolt threads, assemble the motor sub-assembly to the strainer pot-pump body by using the two through bolts for proper alignment. Do not tighten the through bolts until all 4 bolts are in place and finger tightened.
9. Fill the pump with water.
10. Reinstall the pump lid and plastic clamp; see [SECTION 3, Maintenance](#).
11. Reprime the system.

The Shaft Seal

1. The Shaft Seal consists primarily of two parts, a rotating member and a ceramic seal.
2. The pump requires little or no service other than reasonable care, however, a Shaft Seal may occasionally become damaged and must be replaced.

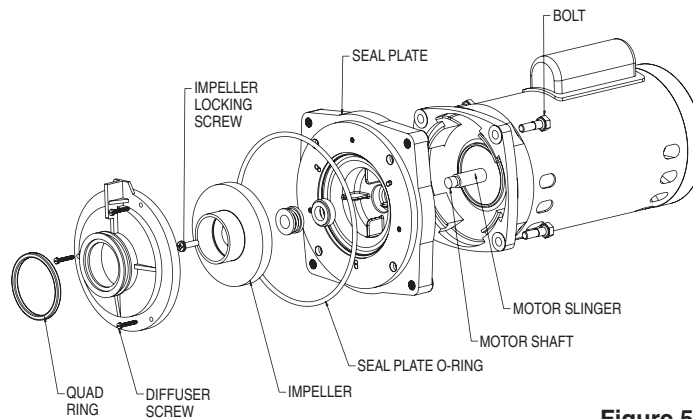



Figure 5.

Section 5

Restart Instructions

If the SuperFlo® pump is installed below the water level of the pool, close return and suction lines prior to opening hair and lint pot on pump. Make sure to reopen valves prior to operating.

 **CAUTION** — DO NOT run the pump dry. If the pump is run dry, the mechanical seal will be damaged and the pump will start leaking. If this occurs, the damaged seal must be replaced. ALWAYS maintain proper water level in your pool (half way up skimmer opening). If the water level falls below the skimmer opening, the pump will draw air through the skimmer, losing the prime and causing the pump to run dry, resulting in a damaged seal. Continued operation in this manner could cause a loss of pressure, resulting in damage to the pump case, impeller and seal, and may cause property damage and personal injury.

Priming the Pump

1. The pump strainer pot must be filled with water before the pump is initially started. Follow these steps to prime the pump.
 - a. Remove the pump lid plastic clamp. Remove the pump lid.
 - b. Fill the pump strainer pot with water.
 - c. Reassemble the pump cover and plastic clamp onto the strainer pot. The pump is now ready to prime.
 - d. Open the air release valve on the filter, and stand clear of the filter.
 - e. Turn on the switch or time clock.
 - f. When water comes out of the air release valve, close the valve. The system should now be free of air and recirculating water to and from the pool.
2. For 2-speed pumps:
 - a. Pump should run on high-speed for priming.
 - b. The pump should not run longer than 8 minutes before priming is achieved.

Section 6

Troubleshooting

Use the following troubleshooting information to resolve possible problems with your SuperFlo® pump.

WARNING — RISK OF ELECTRICAL SHOCK OR ELECTROCUTION.

Improperly installation will create an electrical hazard which could result in death or serious injury to pool users, installers, or others due to electrical shock, and may also cause damage to property.



1. If you are not familiar with your pool filtering system and/or heater:
 - a. **Do NOT** attempt to adjust or service without consulting your dealer, or a qualified pool technician.
 - b. Read the entire Installation & User's Guide before attempting to use, service or adjust the pool filtering system or heater.

Note: Turn off power to unit prior to attempting service or repair.

Problems and Corrective Actions

<i>Problem</i>	<i>Corrective Action</i>
FAILURE TO PUMP Pump Will Not Prime — to much air	Check suction piping and valve glands on any suction gate valves. Secure lid on pump strainer pot and make sure lid gasket is in place. Check water level to make sure skimmer is not drawing air.
Pump Will Not Prime — not enough water Pump strainer clogged	Make sure suction lines, pump strainer, and pump volute are full of water. Make sure valve on suction line is working and open, (some systems do not have valves). Check water level to make sure water is available through skimmer. Clean pump strainer pot.
Pump strainer gasket defective	Replace gasket.
REDUCED CAPACITY and/or HEAD Air pockets or leaks in suction line Pump Will Not Prime — to much air	Check suction piping and valve glands on any suction gate valves. Secure lid on pump strainer pot and make sure lid gasket is in place. Check water level to make sure skimmer is not drawing air.
Clogged impeller	Turn off electrical power to the pump. Remove the clamp that holds the volute to the seal plate. Slide the motor and seal plate away from the volute. Clean debris from impeller. If debris cannot be removed, complete the following steps. <ol style="list-style-type: none"> (1) Remove left hand thread anti-spin bolt and O-ring. (2) Remove, clean and reinstall impeller. (3) Reinstall anti-spin bolt. Reinstall diffuser and quad ring. Reinstall motor and seal plate into volute. Reinstall clamp around seal plate and volute and tighten securely.
Pump strainer clogged	Clean suction trap.

Section 7

Technical Data

Illustrated Parts List

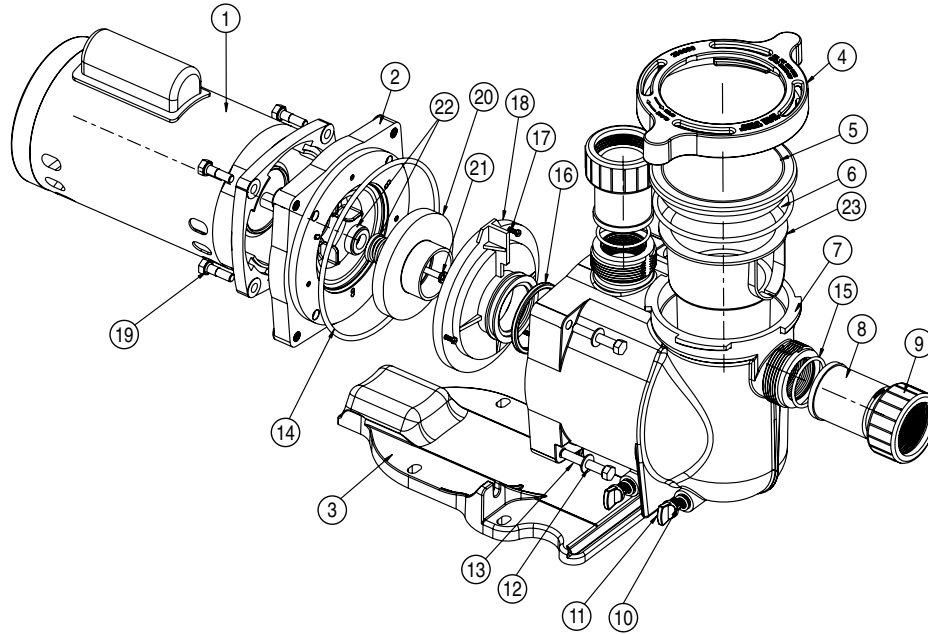

Item No.	Part No.	Description	Item No.	Part No.	Description
SINGLE SPEED SUPERFLO MOTORS			12	355621	SCREW 3/4-16 X 2 1/4 HEX HD, 4 req.
1	355018S	1/2, 3/4 HP — (Almond)	13	072184	WASHER 3/8 in. S/S, 4 req.
1	355020S	1 HP — (Almond)	14	355619	O-RING SEAL BRACKET
1	355022S	1 1/2 HP — (Almond)	15	350099	O-RING ADAPTER #2-226, 2 req.
1	355024S	2 HP — (Almond)	16	355030	SEAL DIFFUSER
1	355026S	2 1/2 HP — (Almond)	17	355334	SCREW #8-32 HEX WASHER HD, 3 req.
DUAL SPEED SUPERFLO MOTORS			18	355617	DIFFUSER - 1/2 HP
1	350088S	3/4 HP 115 VOLTAGE — (Almond)	18	355617	DIFFUSER - 3/4 HP
1	355003S	1 HP — (Almond)	18	355617	DIFFUSER - 1 HP
1	356630S	1 1/2 HP — (Almond)	18	355618	DIFFUSER - 1 1/2 HP
1	071320S	2 HP — (Almond)	18	355618	DIFFUSER - 2 HP
ENERGY EFFICIENT SUPERFLO MOTORS			18	350170	DIFFUSER - 2 1/2 HP
1	071313S	1/2, 3/4, 1 HP — (Almond)	19	354290	HEX HEAD SCREW 3/8 - 16, 4 req.
1	071314S	1 1/2 HP — (Almond)	20	355043	IMPELLER 1/2 HP
1	071315S	2 HP — (Almond)	20	355043	IMPELLER 3/4 HP
1	071316S	2 1/2 HP — (Almond)	20	355067	IMPELLER 1 HP
2	356012	SEAL PLATE	20	355074	IMPELLER 1 1/2 HP
3	350094	BASE	20	355086	IMPELLER 2 HP
4	350090	CLAMP, RAMP & CAM	20	355093	IMPELLER 2 1/2 HP
5	350091	LID	20	355067	IMPELLER 1 HP, 2-SPD
6	357255	O-RING, LID #2-357	20	355074	IMPELLER 1 1/2 HP, 2-SPD
7	350089	VOLUTE	20	355086	IMPELLER 2 HP, 2-SPD
8	350093	ADAPTER, 2 req.	21	355389	SCREW, IMPELLER LOCKING
9	350092	NUT, 2 req.	22	354545	SEAL SET
10	192115	O-RING DRAIN PLUG, 2 req.	23	355667	BASKET, LARGE
11	071131	DRAIN PLUG, 2 req.	24	350157	KIT UNION SUPERFLO® (Items No. 8, 9, 15)

Pump Curve

Pentair Water Pool and Spa, Inc.
Pump Performance Curve
SuperFlo® Series

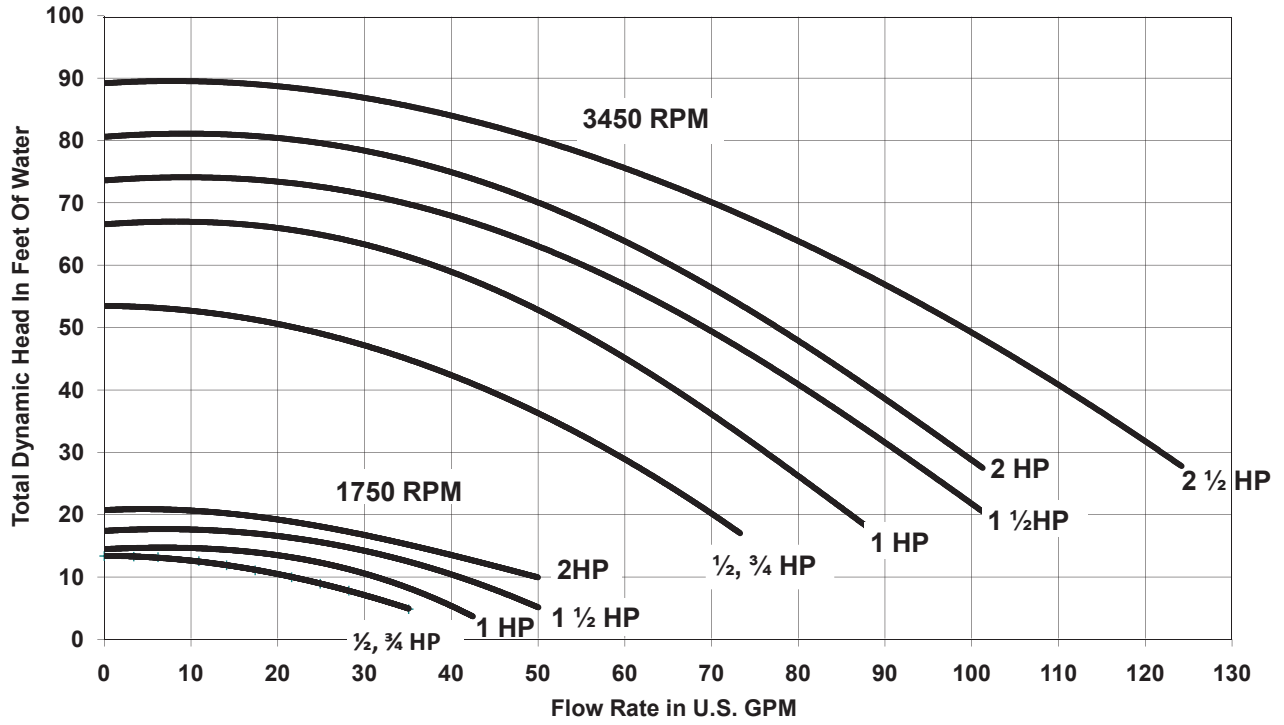



SUPERFLO® HIGH PERFORMANCE PUMP

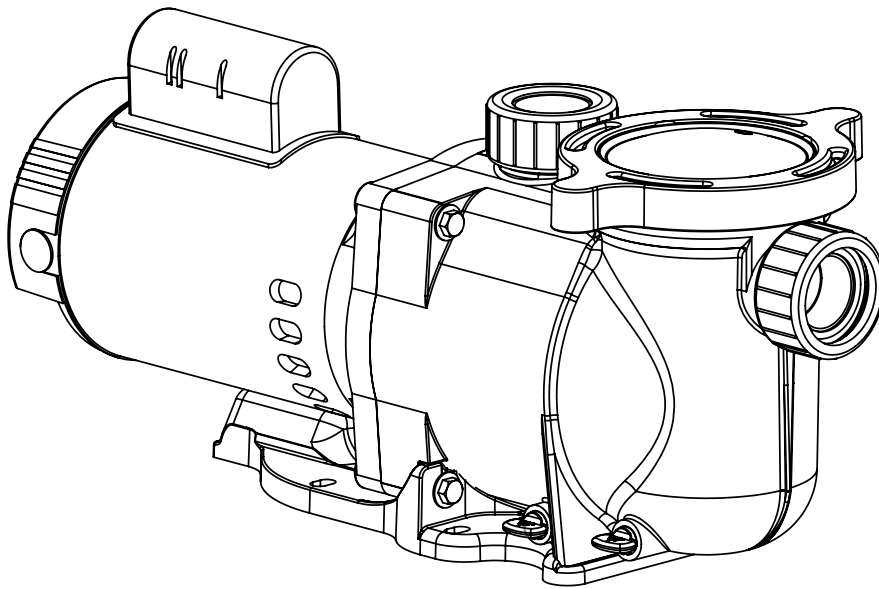

ENGLISH 1

ESPAÑOL 11

INSTALLATION AND USER'S GUIDE

IMPORTANT SAFETY INSTRUCTIONS
READ AND FOLLOW ALL INSTRUCTIONS
SAVE THESE INSTRUCTIONS

CUSTOMER SERVICE / TECHNICAL SUPPORT

If you have questions about ordering Pentair Aquatic Systems replacement parts, and pool products, please contact:

Customer Service and Technical Support, USA

(8 A.M. to 4:30 P.M. — Eastern/Pacific Times)

Phone: (800) 831-7133

Fax: (800) 284-4151

Web site

Visit www.pentairpool.com or www.staritepool.com to find information about Pentair products.

Sanford, North Carolina (8 A.M. to 4:30 P.M. ET)

Phone: (919) 566-8000

Fax: (919) 566-8920

Moorpark, California (8 A.M. to 4:30 P.M. PT)

Phone: (805) 553-5000 (Ext. 5591)

Fax: (805) 553-5515

TABLE OF CONTENTS

Important Pump Warning and Safety Instructions	ii	Servicing	5
Pump Overview	1	Electric Motor Care	5
Pump Overview	1	Shaft Seal Replacement	5
General Features	1	Pump Disassembly	5
Pump Performance Curves	1	Pump Reassembly	6
Installation	2	Restart Instructions	6
Location	2	Priming the Pump	6
Piping	2	Troubleshooting	7
Fittings and Valves	2	Replacement Parts	8
Electrical Wiring Installation	3		
Maintenance	4		
Pump Strainer Basket	4		
Cleaning the Pump Strainer Basket	4		
Winterizing	4		



IMPORTANT PUMP WARNING AND SAFETY INSTRUCTIONS



IMPORTANT NOTICE

This guide provides installation and operation instructions for this product. Consult Pentair with any questions regarding this equipment.

Attention Installer: This guide contains important information about the installation, operation and safe use of this product. This information should be given to the owner and/or operator of this equipment after installation or left on or near the pump.

Attention User: This manual contains important information that will help you in operating and maintaining this product. Please retain it for future reference. Warnings and safety instructions for Pentair Aquatic Systems pumps and other related products are available at:

<http://www.pentairpool.com/pool-owner/safety-warnings/> or call (800) 831-7133 for additional free copies of these instructions.

READ AND FOLLOW ALL INSTRUCTIONS SAVE THESE INSTRUCTIONS



This is the safety alert symbol. When you see this symbol on your system or in this manual, look for one of the following signal words and be alert to the potential for personal injury.

⚠ DANGER

Warns about hazards that can cause death, serious personal injury, or major property damage if ignored.

⚠ WARNING

Warns about hazards that may cause death, serious personal injury, or major property damage if ignored.

⚠ CAUTION

Warns about hazards that may or can cause minor personal injury or property damage if ignored.

NOTE indicates special instructions not related to hazards.

Carefully read and follow all safety instructions in this manual and on equipment. Keep safety labels in good condition; replace if missing or damaged.

When installing and using this electrical equipment, basic safety precautions should always be followed, include the following:

⚠ WARNING Do not permit children to use this product.

⚠ WARNING RISK OF ELECTRICAL SHOCK. Connect only to a branch circuit protected by a ground-fault circuit-interrupter (GFCI). Contact a qualified electrician if you cannot verify that the circuit is protected by a GFCI.

⚠ WARNING This unit must be connected only to a supply circuit that is protected by a ground-fault circuit-interrupter (GFCI). Such a GFCI should be provided by the installer and should be tested on a routine basis. To test the GFCI, push the test button. The GFCI should interrupt power. Push the reset button. Power should be restored. If the GFCI fails to operate in this manner, the GFCI is defective. If the GFCI interrupts power to the pump without the test button being pushed, a ground current is flowing, indicating the possibility of an electric shock. Do not use this pump. Disconnect the pump and have the problem corrected by a qualified service representative before using.

⚠ CAUTION This pump is for use with permanent swimming pools and may also be used with hot tubs and spas if so marked. Do not use with storable pools. A permanently-installed pool is constructed in or on the ground or in a building such that it cannot be readily disassembled for storage. A storable pool is constructed so that it is capable of being readily disassembled for storage and reassembled to its original integrity.

General Warnings

- Never open the inside of the drive motor enclosure. There is a capacitor bank that holds a 230 VAC charge even when there is no power to the unit.
- The pump is not submersible.
- The pump is capable of high flow rates; use caution when installing and programming to limit pumps performance potential with old or questionable equipment.
- Code requirements for the electrical connection differ from state to state. Install equipment in accordance with the current National Electrical Code and all applicable local codes and ordinances.
- Before servicing the pump; switch OFF power to the pump by disconnecting the main circuit to the pump.
- This appliance is not intended for use by persons (including children) of reduced physical, sensory or mental capabilities, or lack of experience and knowledge, unless they have been given supervision or instruction concerning the use of the appliance by a person responsible for their safety.

⚠ DANGER FAILURE TO FOLLOW ALL INSTRUCTIONS AND WARNINGS CAN RESULT IN SERIOUS BODILY INJURY OR DEATH. **THIS PUMP SHOULD BE INSTALLED AND SERVICED ONLY BY A QUALIFIED POOL SERVICE PROFESSIONAL. INSTALLERS, POOL OPERATORS AND OWNERS MUST READ THESE WARNINGS AND ALL INSTRUCTIONS IN THE OWNER'S MANUAL BEFORE USING THIS PUMP. THESE WARNINGS AND THE OWNER'S MANUAL MUST BE LEFT WITH THE POOL OWNER.**

⚠ DANGER SUCTION ENTRAPMENT HAZARD: STAY OFF THE MAIN DRAIN AND AWAY FROM ALL SUCTION OUTLETS!

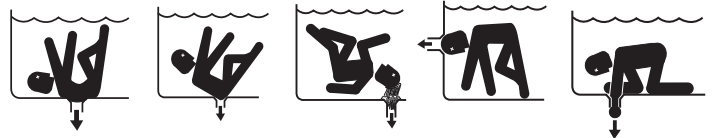

THIS PUMP PRODUCES HIGH LEVELS OF SUCTION AND CREATES A STRONG VACUUM AT THE MAIN DRAIN AT THE BOTTOM OF THE BODY OF WATER. THIS SUCTION IS SO STRONG THAT IT CAN TRAP ADULTS OR CHILDREN UNDER WATER IF THEY COME IN CLOSE PROXIMITY TO A DRAIN OR A LOOSE OR BROKEN DRAIN COVER OR GRATE.

⚠ DANGER **RISK OF ELECTRICAL SHOCK OR ELECTROCUTION: PUMPS REQUIRE HIGH VOLTAGE WHICH CAN SHOCK, BURN, OR CAUSE DEATH. BEFORE WORKING ON PUMP!** Always disconnect power to the pool pump at the circuit breaker from the pump before servicing the pump. Failure to do so could result in death or serious injury to service person, pool users or others due to electric shock.



THE USE OF UNAPPROVED COVERS OR ALLOWING USE OF THE POOL OR SPA WHEN COVERS ARE MISSING, CRACKED OR BROKEN CAN RESULT IN BODY OR LIMB ENTRAPMENT, HAIR ENTANGLEMENT, BODY ENTRAPMENT, EVISCERATION AND/OR DEATH. The suction at a drain or outlet can cause:

Limb Entrapment: When a limb is sucked or inserted into an opening resulting in a mechanical bind or swelling. This hazard is present when a drain cover is missing, broken, loose, cracked or not properly secured.

Hair Entanglement: When the hair tangles or knots in the drain cover, trapping the swimmer underwater. This hazard is present when the flow rating of the cover is too small for the pump or pumps.

IMPORTANT PUMP WARNING AND SAFETY INSTRUCTIONS

Body Entrapment: When a portion of the body is held against the drain cover trapping the swimmer underwater. This hazard is present when the drain cover is missing, broken or the cover flow rating is not high enough for the pump or pumps.

Evisceration/Disembowelment: When a person sits on an open pool (particularly a child wading pool) or spa outlet and suction is applied directly to the intestines, causing severe intestinal damage. This hazard is present when the drain cover is missing, loose, cracked, or not properly secured.

Mechanical Entrapment: When jewelry, swimsuit, hair decorations, finger, toe or knuckle is caught in an opening of an outlet or drain cover. This hazard is present when the drain cover is missing, broken, loose, cracked, or not properly secured.

NOTE: ALL SUCTION PLUMBING MUST BE INSTALLED IN ACCORDANCE WITH THE LATEST NATIONAL AND LOCAL CODES, STANDARDS AND GUIDELINES.

WARNING TO MINIMIZE THE RISK OF INJURY DUE TO SUCTION ENTRAPMENT HAZARD:

- A properly installed and secured ANSI/ASME A112.19.8 approved anti-entrapment suction cover must be used for each drain.
- Each suction cover must be installed at least three (3') feet apart, as measured from the nearest point to nearest point.
- Regularly inspect all covers for cracks, damage and advanced weathering.
- If a cover becomes loose, cracked, damaged, broken or is missing, replace with an appropriate certified cover.
- Replace drain covers as necessary. Drain covers deteriorate over time due to exposure to sunlight and weather.
- Avoid getting hair, limbs or body in close proximity to any suction cover, pool drain or outlet.
- Disable suction outlets or reconfigure into return inlets.

WARNING A clearly labeled emergency shut-off switch for the pump must be in an easily accessible, obvious place. Make sure users know where it is and how to use it in case of emergency.

The Virginia Graeme Baker (VGB) Pool and Spa Safety Act creates new requirements for owners and operators of commercial swimming pools and spas.

Commercial pools or spas constructed on or after December 19, 2008, shall utilize:

(A) A multiple main drain system without isolation capability with suction outlet covers that meet ASME/ANSI A112.19.8a Suction Fittings for Use in Swimming Pools, Wading Pools, Spas, and Hot Tubs and either:

- (i) A safety vacuum release system (SVRS) meeting ASME/ANSI A112.19.17 Manufactured Safety Vacuum Release systems (SVRS) for Residential and Commercial Swimming Pool, Spa, Hot Tub, and Wading Pool Suction Systems and/or ASTM F2387 Standard Specification for Manufactured Safety Vacuum Release Systems (SVRS) for Swimming pools, Spas and Hot Tubs or
- (ii) A properly designed and tested suction-limiting vent system or
- (iii) An automatic pump shut-off system.

Commercial pools and spas constructed prior to December 19, 2008, with a single submerged suction outlet shall use a suction outlet cover that meets ASME/ANSI A112.19.8a and either:

- (A) A SVRS meeting ASME/ANSI A112.19.17 and/or ASTM F2387, or
- (B) A properly designed and tested suction-limiting vent system, or
- (C) An automatic pump shut-off system, or
- (D) Disabled submerged outlets, or
- (E) Suction outlets shall be reconfigured into return inlets.

For Installation of Electrical Controls at Equipment Pad (ON/OFF Switches, Timers and Automation Load Center)

CAUTION



Install all electrical controls at equipment pad, such as on/off switches, timers, and control systems, etc. to allow the operation (startup, shut-down, or servicing) of any pump or filter so the user does not place any portion of his/her body over or near the pump strainer lid, filter lid or valve closures. This installation should allow the user enough space to stand clear of the filter and pump during system start-up, shut down or servicing of the system filter.

DANGER



HAZARDOUS PRESSURE: STAND CLEAR OF PUMP AND FILTER DURING START UP

Circulation systems operate under high pressure. When any part of the circulating system (i.e. locking ring, pump, filter, valves, etc.) is serviced, air can enter the system and become pressurized.

Pressurized air can cause the pump housing cover filter lid and valves to violently separate which can result in severe personal injury or death. Filter tank lid and strainer cover must be properly secured to prevent violent separation. Stand clear of all circulation system equipment when turning on or starting up pump.

Before servicing equipment, make note of the filter pressure. Be sure that all controls are set to ensure the system cannot inadvertently start during service. Turn off all power to the pump. **IMPORTANT: Place filter manual air relief valve in the open position and wait for all pressure in the system to be relieved.**

Before starting the system, fully open the manual air relief valve and place all system valves in the "open" position to allow water to flow freely from the tank and back to the tank. Stand clear of all equipment and start the pump. **IMPORTANT: Do not close filter manual air relief valve until all pressure has been discharged from the valve and a steady stream of water appears.** Observe filter pressure gauge and be sure it is not higher than the pre-service condition.

General Installation Information

- All work must be performed by a qualified service professional, and must conform to all national, state, and local codes.
- Install to provide drainage of compartment for electrical components.
- These instructions contain information for a variety of pump models and therefore some instructions may not apply to a specific model. All models are intended for use in swimming pool applications. The pump will function correctly only if it is properly sized to the specific application and properly installed.

WARNING

Pumps improperly sized or installed or used in applications other than for which the pump was intended can result in severe personal injury or death. These risks may include but not be limited to electric shock, fire, flooding, suction entrapment or severe injury or property damage caused by a structural failure of the pump or other system component.

WARNING

The pump can produce high levels of suction within the suction side of the plumbing system. These high levels of suction can pose a risk if a person comes within the close proximity of the suction openings. A person can be seriously injured by this high level of vacuum or may become trapped and drown. It is absolutely critical that the suction plumbing be installed in accordance with the latest national and local codes for swimming pools.

SAVE THESE INSTRUCTIONS

PUMP OVERVIEW

Pump Overview

The perfect choice for all types of pools, the SuperFlo® High Performance Pump was specifically designed to be your best choice for a variety of inground pools.

Thick walled body parts, a heavy duty 56 square flange motor, and highly engineered hydraulics make this rugged and tested design perfect for any pool, spa, water feature, or fountain.

All pumps from Pentair Aquatic Systems incorporate innovative hydraulic engineering that has been refined for over 40 years. Compact, rugged, and easy to maintain, the SuperFlo pump will deliver years of reliable service.

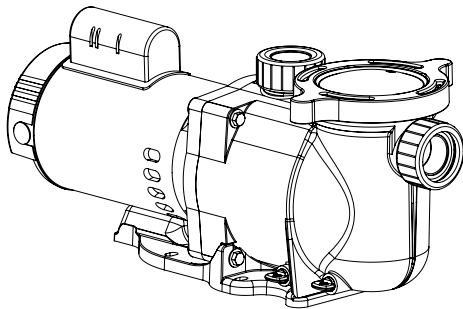

SuperFlo® High Performance Pump

General Features

- Extremely quiet operation
- Unionized fittings (1.5" and 2") for simple replacement
- Cam and Ramp™ Lid for easy cleaning and maintenance
- Heavy-duty, high service factor 56 square flange motor for long life
- Integral volute and pot reduce hydraulic noise
- See-through lid permits easy inspection of strainer basket
- 115 volt or 230 volt models available
- 1/2 Hp to 2 1/2 Hp configurations to accommodate a wide range of applications
- Self-priming for quick, easy start-up
- UL/CUL/NSF

ENGLISH

Pump Performance Curves

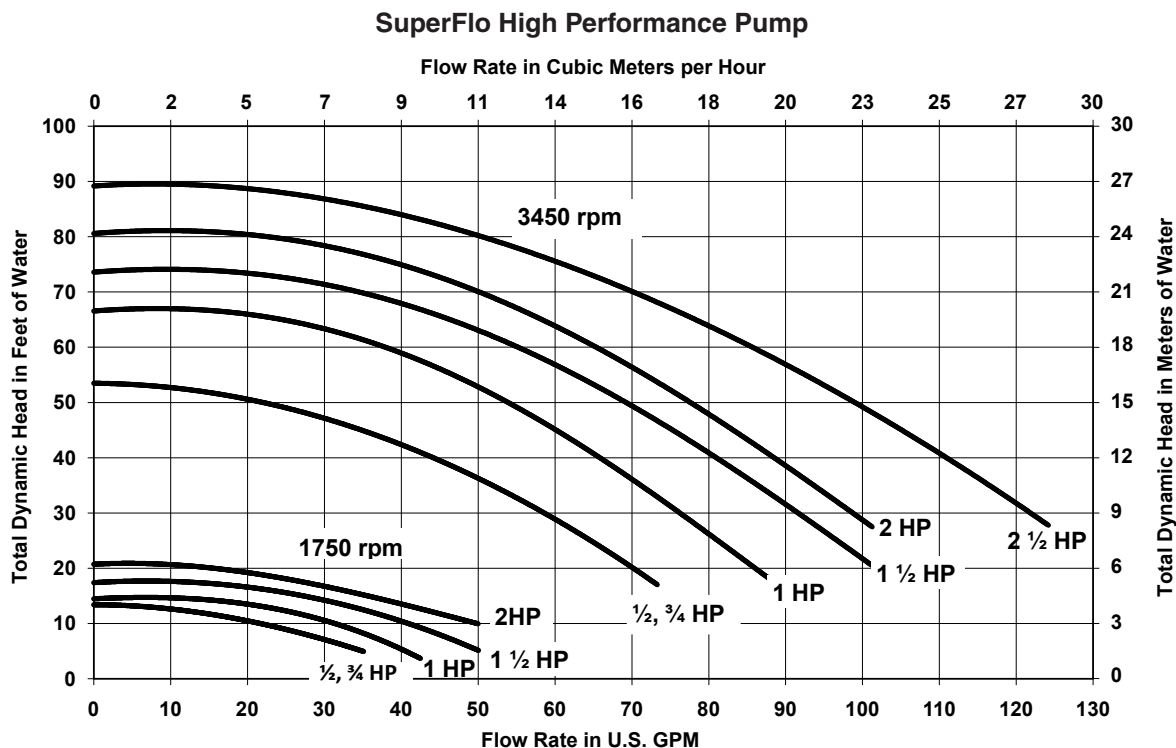

INSTALLATION

Only a qualified plumbing professional should install the SuperFlo® High Performance Pump. Refer to “*Pump Warning And Safety Instructions*” on pages iii - iv for additional installation and safety information.

Location

Be sure the pump location meets the following requirements:

Note: Do not install this pump within an outer enclosure or beneath the skirt of a hot tub or spa unless marked accordingly.

1. Install the pump as close to the pool or spa as possible. To reduce friction loss and improve efficiency, use short, direct suction piping returns.
2. Install a minimum of 5 feet (1.52 meters) from the inside wall of the pool and spa. Canadian installations require a minimum of 9.8 feet (3 meters) from pool water level.
3. Install the pump a minimum of 3 feet (.9 meters) from the heater outlet.
4. Do not install the pump more than 10 feet (3 meters) above the water level.
5. Install the pump in a well ventilated location protected from excessive moisture (i.e., rain gutter downspouts, sprinklers, etc.)
6. Install the pump with a rear clearance of at least 3 inches (76.2 mm) so that the motor can be removed easily for maintenance and repair.

Piping

1. For improved pool plumbing, it is recommended to use a larger pipe size. When installing the inlet and outlet fittings (male adaptors), use thread sealant.
2. Piping on the suction side of the pump should be the same or larger than the return line diameter.
3. Plumbing on the suction side of the pump should be as short as possible.
4. It is recommended that a valve, elbow or tee installed in the suction line should be no closer to the front of the pump than five (5) times the suction line pipe diameter

Example:

A 2 inch (50.8 mm) pipe requires a 10 inch (254 mm) straight run in front of the suction inlet of the pump. This will help the pump prime faster and last longer.

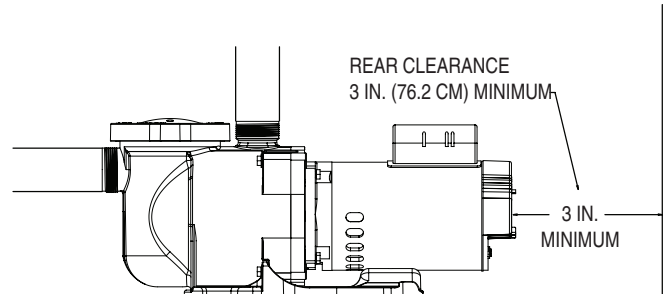

Pump Rear Clearance

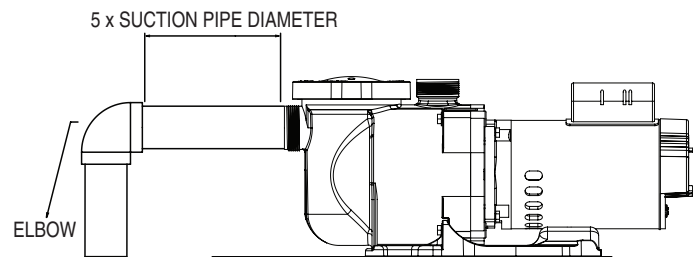

Recommended Piping

Fittings and Valves

1. Do not install 90° elbows directly into pump inlet.
2. Flooded suction systems should have gate valves installed on suction and discharge pipes for maintenance, however, the suction gate valve should be no closer than five times the suction pipe diameter as described in this section.
3. Use a check valve in the discharge line when using this pump for any application where there is significant height to the plumbing after the pump.
4. Be sure to install check valves when plumbing in parallel with another pump. This helps prevent reverse rotation of the impeller and motor.

WARNING

RISK OF ELECTRICAL SHOCK OR ELECTROCUTION. This pump must be installed by a licensed or certified electrician or a qualified service professional in accordance with the National Electrical Code and all applicable local codes and ordinances. Improper installation will create an electrical hazard which could result in death or serious injury to users, installers, or others due to electrical shock, and may also cause damage to property.

Always disconnect power to the pump at the circuit breaker before servicing the pump. Failure to do so could result in death or serious injury to service people, pool users or others due to electric shock and/or property damage.
Read all servicing instructions before working on the pump.

Electrical Wiring Installation

1. Be sure all electrical breakers and switches are turned off before wiring motor.
2. Be sure that the wiring voltage matches the motor voltage (230 VAC or 115 VAC). If they do not match, the motor can overheat.
3. Use the correct wire size and type specified by the current National Electrical Code. When in doubt use a heavier gauge (larger diameter) wire. Heavier gauge will allow the motor to run cooler and more efficient.
4. Be sure all electrical connections are clean and tight.
5. Cut wires to the appropriate length so they do not overlap or touch when connected to the terminal board.
6. Permanently ground the motor using the green ground terminal located on the inside of the motor canopy or access plate, see image. Use the correct wire size and type specified by the current National Electrical Code. Be sure the ground wire is connected to an electrical service ground.
7. Bond the motor to the pool structure in accordance with the current National Electrical Code. UL requires use of a solid copper bonding conductor not smaller than 8 AWG.
8. Connect the wire from the accessible wire connector on the motor to all metal parts of the swimming pool, spa, or hot tub structure and to all electrical equipment, metal conduit, and metal piping within 5 feet (1.52 meters) of the inside walls of the swimming pool, spa, or hot tub. For Canada, a 6 AWG or larger solid copper bonding conductor is required.
9. The pump should be permanently connected to either a circuit breaker, 2-pole timer or 2-pole relay. If AC power is supplied by a GFCI circuit breaker, use a dedicated circuit breaker that has no other electrical loads.
10. Connect the pump permanently to a circuit. Make sure no other lights or appliances are on the same circuit.

Note: When the pump is started and stopped by removing power with a relay or timer, a two-pole device should be used to apply and remove power to both **POWER LINE TERMINALS**.

Note: When pump is mounted permanently within 5 ft. (1.52 meters) of the inside walls of a swimming pool, you must use a No. 8 AWG or larger conductor to connect to bonding conductor lug.

Pentair offers 2-Pole 20 Amp GFCI breakers (P/N PA220GF) which offer 6 milliamp personnel protection while meeting 2008 to current NEC Standards for Pool Pumps.

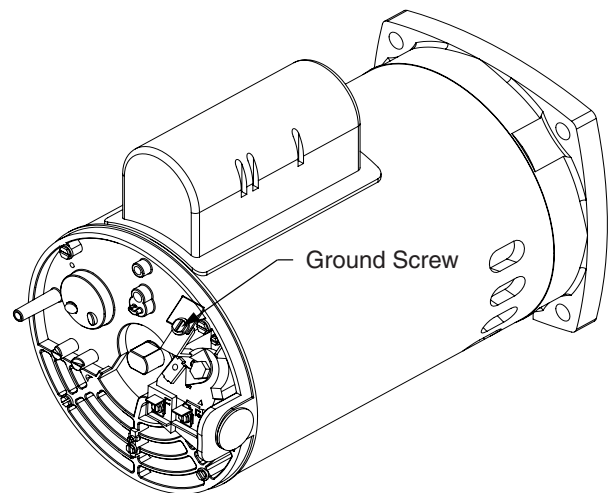

Field Wiring Compartment

MAINTENANCE



WARNING

DO NOT open the strainer pot if pump fails to prime or if pump has been operating without water in the strainer pot. Pumps operated in these circumstances may experience a build up of vapor pressure and may contain scalding hot water. Opening the pump may cause serious personal injury. In order to avoid the possibility of personal injury, make sure the suction and discharge valves are open and strainer pot temperature is cool to touch, then open with extreme caution.



CAUTION

To prevent damage to the pump and for proper operation of the system, clean pump strainer and skimmer baskets regularly.

Pump Strainer Basket

The pump strainer basket (or 'strainer pot', 'hair and lint pot'), is located in front of the volute. Inside the chamber is the basket which must be kept clean of leaves and debris at all times. View basket through the 'See Through Lid' to inspect for leaves and debris.

Regardless of the length of time between filter cleaning, it is most important to visually inspect the basket at least once a week. A dirty basket will reduce the efficiency of the filter and heater and also put an abnormal stress on the pump motor which would result in a costly repair bill.

Cleaning the Pump Strainer Basket

1. Turn off the pump at the circuit breaker.
2. Relieve pressure in the system by allowing the water to cool.
3. Gently tap the clamp in a counter-clockwise direction to remove the clamp and lid.
4. Remove debris and rinse out the basket. Replace the basket if it is cracked.
5. Put the basket back into the housing. Be sure to align the notch in the bottom of the basket with the rib in the bottom of the volute.
6. Fill the pump pot and volute up to the inlet port with water.
7. Clean the cover, O-ring, and sealing surface of the pump pot. **Note:** It is important to keep the lid O-ring clean and well lubricated.
8. Reinstall the lid by placing the lid on the pot. Be sure the lid O-ring is properly placed. Seat the clamp and lid on the pump then turn clockwise until the handles are horizontal.
9. Turn the power "ON" at the house circuit breaker. Reset the pool time clock to the correct time.
10. Open the High Flow manual air relief valve on top of the filter.
11. Stand clear of the filter. Start the pump.
12. Bleed air from the filter until a steady stream of water comes out. Close the High Flow™ Manual Air Relief Valve.



WARNING

THIS SYSTEM OPERATES UNDER HIGH PRESSURE. When any part of the circulating system (e.g., Lock Ring, Pump, Filter, Valves, etc.) is serviced, air can enter the system and become pressurized. Pressurized air can cause the lid to separate which can result in serious injury, death, or property damage. To avoid this potential hazard, follow above instructions.



Winterizing

You are responsible for determining when freezing conditions may occur. If freezing conditions are expected, take the following steps to reduce the risk of freeze damage. **Freeze damage is not covered under warranty.**

To prevent freeze damage, follow the procedures below:

1. Shut off electrical power for the pump at the circuit breaker.
2. Drain the water out of the pump housing by removing the two thumb-twist drain plugs from the housing. Store the plugs in the pump basket.
3. Cover the motor to protect it from severe rain, snow and ice.

Note: Do not wrap motor with plastic or other air tight materials during winter storage. The motor may be covered during a storm, winter storage, etc., but never when operating or expecting operation.

In mild climate areas, when temporary freezing conditions may occur, run your filtering equipment all night to prevent freezing.

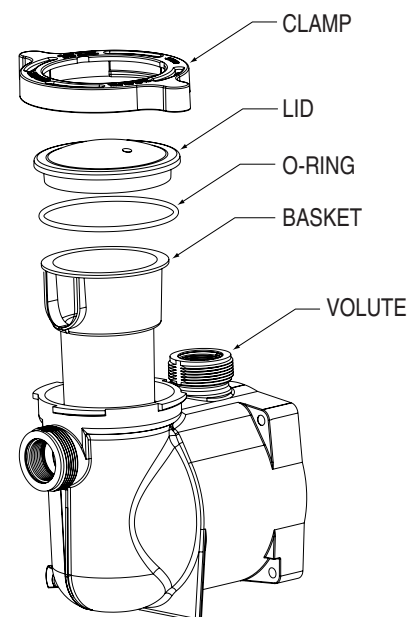

Strainer Pot Assembly

**WARNING**

Always disconnect power to the pump at the circuit breaker and disconnect the communication cable before servicing the pump. Failure to do so could result in death or serious injury to service people, users or others due to electric shock. Read all servicing instructions before working on the pump.

**WARNING**

DO NOT open the strainer pot if pump fails to prime or if pump has been operating without water in the strainer pot. Pumps operated in these circumstances may experience a build up of vapor pressure and may contain scalding hot water. Opening the pump may cause serious personal injury. In order to avoid the possibility of personal injury, make sure the suction and discharge valves are open and strainer pot temperature is cool to touch, then open with extreme caution.

**CAUTION**

Be sure not to scratch or mar the polished shaft seal faces; seal will leak if faces are damaged. The polished and lapped faces of the seal could be damaged if not handled with care.

Care of Electric Motor

Protect from heat

1. Shade the motor from the sun.
2. Any enclosure must be well ventilated to prevent overheating.
3. Provide ample cross ventilation.

Protect against dirt

1. Protect from any foreign matter or splashing water.
2. Do not store (or spill) chemicals on or near the motor.
3. Protect from any foreign matter or splashing water.
4. Avoid sweeping or stirring up dust near the motor while it is operating.
5. If a motor has been damaged by dirt it voids the motor warranty.
6. Clean the lid and clamp, O-ring, and sealing surface of the pump pot.

Protect against moisture

1. Protect from splashing or sprayed water.
2. Protect from extreme weather.
3. Protect from any foreign matter or splashing water.
4. If a motor has become wet - let it dry before operating. Do not allow the pump to operate if it has been flooded.
5. If a motor has been damaged by water it voids the motor warranty.

Note: When replacing the motor, be certain that the motor support is correctly positioned to support the size of motor being installed.

Shaft Seal Replacement

The Shaft Seal consists primarily of two parts, a rotating member and a ceramic seal.

The pump requires little or no service other than reasonable care, however, a Shaft Seal may occasionally become damaged and must be replaced.

Note: The polished and lapped faces of the seal could be damaged if not handled with care.

Pump Disassembly

All moving parts are located in the rear sub-assembly of this pump.

Tools required:

- 1/4 inch socket or open end wrench.
- 9/16 inch open end wrench.
- 1/2 inch or 7/16 inch open end wrench
- Flat blade screwdriver.

To remove and repair the motor subassembly, follow the steps below:

1. Turn off the pump circuit breaker at the main panel.
2. Drain the pump by removing the drain plugs.
3. Remove the 4 bolts that hold the main pump body (strainer pot/volute) to the rear sub-assembly.
4. GENTLY pull the two pump halves apart, removing the rear sub-assembly.
5. Remove the three hex head screws holding the diffuser in position.
6. Hold the impeller securely in place and remove the impeller lock screw by using a flat blade screwdriver or wrench. The screw is a left-handed thread and loosens in a clockwise direction.
7. Remove the shaft cap located at the back of the motor and hold the shaft secure with a 1/2 inch (Century® motors) or 7/16 inch (Franklin Electric® Motors) open-end wrench. On AO Smith® motors, remove the motor canopy, move the capacitor to one side and hold the shaft with a 7/16 inch open-end wrench.
8. To unscrew the impeller from the shaft, twist the impeller counter-clockwise.
9. Remove the four bolts from the seal plate to the motor using a 9/16 inch wrench.
10. Place the seal plate face down on a flat surface and tap out the ceramic seal.
11. Clean the seal plate, seal housing, and the motor shaft.



DO NOT run the pump dry. If the pump is run dry, the mechanical seal will be damaged and the pump will start leaking. If this occurs, the damaged seal must be replaced. ALWAYS maintain proper water level. If the water level falls below the suction port, the pump will draw air through the suction port, losing the prime and causing the pump to run dry, resulting in a damaged seal. Continued operation in this manner could cause a loss of pressure, resulting in damage to the pump case, impeller and seal and may cause property damage and personal injury.

Pump Reassembly

1. When installing the replacement seal into the seal plate, use soapy water to wet the rubber boot before pressing it into the seal plate.
2. Remount the seal plate to the motor.
3. Before installing the rotating portion of the seal on the motor shaft, wet the motor shaft with soapy water and slide the seal onto the motor shaft. Ensure that the carbon face contacts the ceramic face of the stationary seat. Press the seal into the seal plate with your thumbs and wipe off the ceramic with a clean cloth.
4. Grease the motor shaft thread and screw impeller onto the motor shaft.
5. Screw in the impeller lock screw (counter-clockwise to tighten).
6. Remount the diffuser onto the seal plate. Make sure the plastic pins and holding screw inserts are aligned.
7. Grease the diffuser quad ring and seal plate O-ring prior to reassembly.
8. Grease the bolt threads, assemble the motor sub-assembly to the strainer pot-pump body by using the two through bolts for proper alignment. Do not tighten the through bolts until all 4 bolts are in place and finger tightened.
9. Fill the pump with water.
10. Reinstall the pump lid and plastic clamp; see the next section, 'Restart Instructions'.
11. Reprime the system.

Restart Instructions

If pump is installed below the water level of the pool, close return and suction lines prior to opening hair and lint pot on pump. Make sure to re-open valves prior to operating.

Priming the Pump

The pump strainer pot must be filled with water before the pump is initially started.

Follow these steps to prime the pump:

1. Remove the pump lid plastic clamp. Remove the pump lid.
2. Fill the pump strainer pot with water.
3. Reassemble the pump cover and plastic clamp onto the strainer pot. The pump is now ready to prime.
4. Open the air release valve on the filter, and stand clear of the filter.
5. Turn on the switch or time clock.
6. When water comes out of the air release valve, close the valve. The system should now be free of air and recirculating water to and from the pool.
7. For 2-speed pumps:
 - Pump should run on high-speed for priming.
 - The pump should not run longer than 8 minutes before priming is achieved.

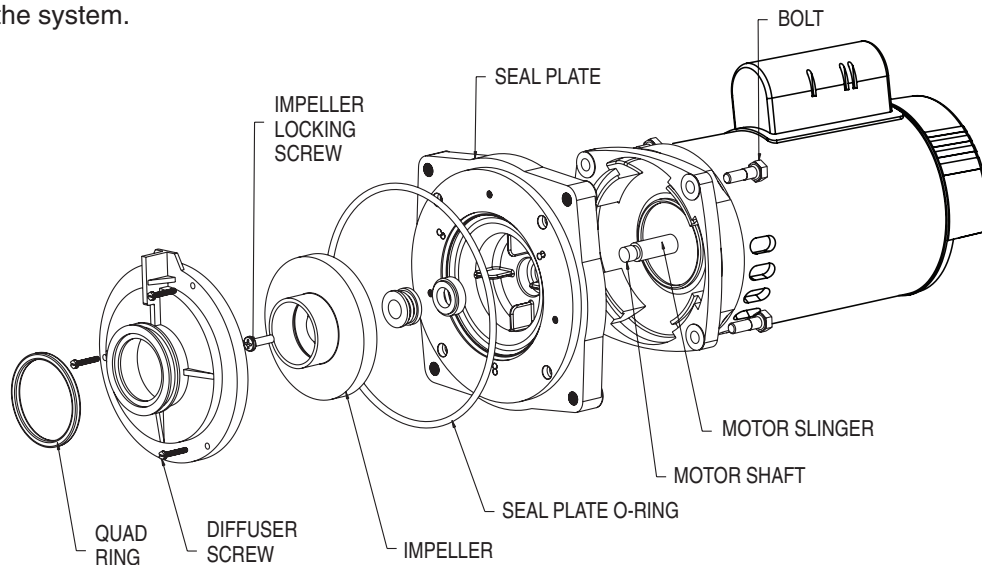

Motor Assembly

TROUBLESHOOTING

Problem	Possible Cause	Corrective Action
Pump failure.	<p>Pump will not prime - Air leak, too much air.</p> <p>Pump will not prime - Not enough water.</p> <p>Pump stainer gasket is clogged.</p> <p>Pump strainer gasket is defective.</p>	<p>Check suction piping and valve glands on any suction gate valves. Secure lid on pump strainer pot and be sure lid gasket is in place. Check water level to be sure skimmer is not drawing air.</p> <p>Be sure the suction lines, pump, strainer, and pump volute are full of water. Be sure valve on suction line is working and open (some systems do not have valves). Check water level to make sure water is available through skimmer.</p> <p>Clean pump strainer pot.</p> <p>Replace gasket.</p>
Reduced capacity and/or head.	<p>Air pockets or leaks in suction line.</p> <p>Clogged impeller.</p> <p>Pump strainer clogged.</p>	<p>Check suction piping and valve glands on any suction gate valves. Secure lid on pump strainer pot and be sure lid gasket is in place. Check water level to be sure skimmer is not drawing air.</p> <p>Turn off electrical power to the pump. Disassemble (see page 5, 'Pump Disassembly')</p> <p>Clean debris from impeller. If debris cannot be removed, complete the following steps:</p> <ol style="list-style-type: none"> 1. Remove left hand thread anti-spin bolt and o-ring. 2. Remove, clean, and reinstall impeller. <p>Reassemble (see page 6, 'Pump Reassembly')</p> <p>Clean suction trap.</p>

REPLACEMENT PARTS

SuperFlo® High Performance Pump Parts List

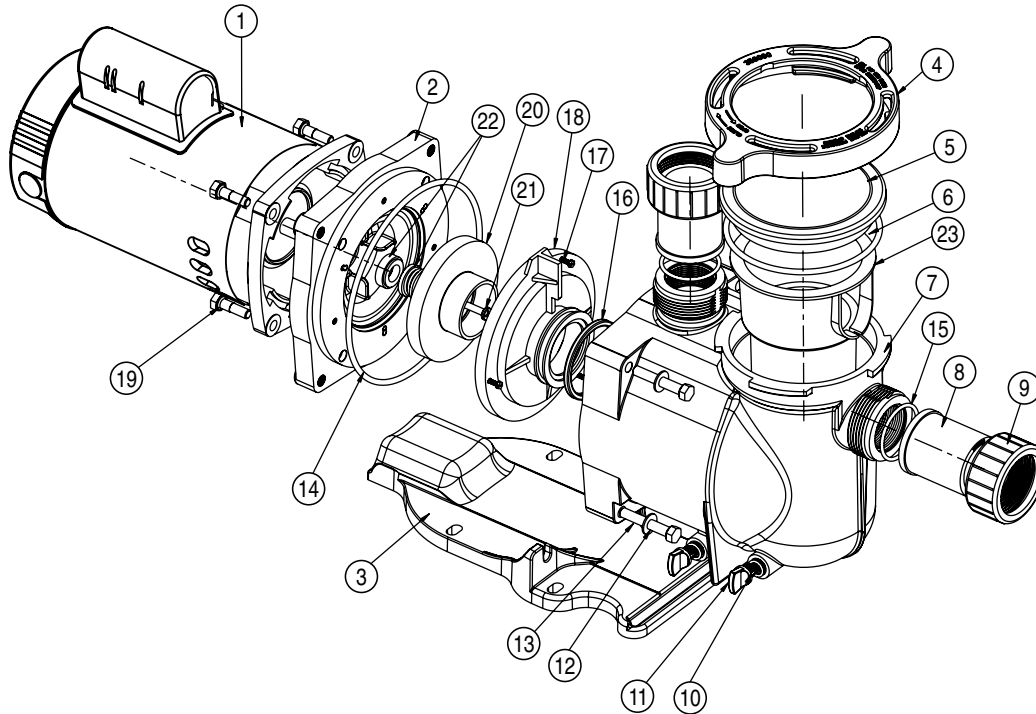

Item No.	Part No.	Description	Item No.	Part No.	Description
SINGLE SPEED SUPERFLO MOTORS					
1	355018S	½, ¾ HP — (Almond)	12	355621	SCREW ¾-16 X 2¼ HEX HD, 4 req.
1	355020S	1 HP — (Almond)	13	072184	WASHER 3/8 in. S/S, 4 req.
1	355022S	1½ HP — (Almond)	14	355619	O-RING SEAL BRACKET
1	355024S	2 HP — (Almond)	15	350099	O-RING ADAPTER #2-226, 2 req.
1	355026S	2½ HP — (Almond)	16	355030	SEAL DIFFUSER
DUAL SPEED SUPERFLO MOTORS					
1	350088S	¾ HP 115 VOLTAGE — (Almond)	17	355334	SCREW #8-32 HEX WASHER HD, 3 req.
1	355003S	1 HP — (Almond)	18	355617	DIFFUSER - ½ HP
1	356630S	1½ HP — (Almond)	18	355617	DIFFUSER - ¾ HP
1	071320S	2 HP — (Almond)	18	355617	DIFFUSER - 1 HP
ENERGY EFFICIENT SUPERFLO MOTORS					
1	355008S	½, ¾, 1 HP — (Almond)	18	355618	DIFFUSER - 1½ HP
1	355010S	1½ HP — (Almond)	18	355618	DIFFUSER - 2 HP
1	355012S	2 HP — (Almond)	18	350170	DIFFUSER - 2½ HP
1	355014S	2½ HP — (Almond)	19	354290	HEX HEAD SCREW 3/8 - 16, 4 req.
2	356012	SEAL PLATE	20	355043	IMPELLER ½ HP
3	350094	BASE	20	355043	IMPELLER ¾ HP
4	350090	CLAMP, RAMP & CAM	20	355067	IMPELLER 1 HP
5	350091	LID	20	355074	IMPELLER 1½ HP
6	357255	O-RING, LID #2-357	20	355086	IMPELLER 2 HP
7	350089	VOLUTE	20	355093	IMPELLER 2½ HP
8	350093	ADAPTER, 2 req.	20	355067	IMPELLER 1 HP, 2-SPD
9	350092	NUT, 2 req.	20	355074	IMPELLER 1½ HP, 2-SPD
10	192115	O-RING DRAIN PLUG, 2 req.	20	355086	IMPELLER 2 HP, 2-SPD
11	071131	DRAIN PLUG, 2 req.	21	355389	SCREW, IMPELLER LOCKING
			22	354545	SEAL SET
			23	355667	BASKET, LARGE
			24	350157	KIT UNION SUPERFLO (Items No. 8, 9, 15)

NOTES



LIT PKG. P/N 354707



1620 HAWKINS AVE., SANFORD, NC 27330 • (919) 566-8000
10951 WEST LOS ANGELES AVE., MOORPARK, CA 93021 • (805) 553-5000

WWW.PENTAIRPOOL.COM

All Pentair trademarks and logos are owned by Pentair or one of its global affiliates. Pentair Aquatic Systems™, SuperFlo®, Cam and Ramp™ and High Flow™ are trademarks and/or registered trademarks of Pentair Water Pool and Spa, Inc. and/or its affiliated companies in the United States and/or other countries. Unless expressly noted, names and brands of third parties that may be used in this document are not used to indicate an affiliation or endorsement between the owners of these names and brands and Pentair Water Pool and Spa, Inc. Those names and brands may be the trademarks or registered trademarks of those third parties. Because we are continuously improving our products and services, Pentair reserves the right to change specifications without prior notice. Pentair is an equal opportunity employer.

© 2015 Pentair Water Pool and Spa, Inc. All rights reserved. This document is subject to change without notice.



P/N 350096 REV. G 6/15/15

Clean & Clear® Cartridge Filter Owners Manual

IMPORTANT SAFETY INSTRUCTIONS *READ AND FOLLOW ALL INSTRUCTIONS* SAVE THESE INSTRUCTIONS

Table of Contents

SECTION I.	FILTER INSTALLATION	1
SECTION II.	FILTER OPERATION	2
SECTION III.	TROUBLESHOOTING.....	6
SECTION IV.	TECHNICAL DATA	7
	A. Filter Pressure Loss Chart.....	7
	C. Replacement Parts	7
	B. Flow Rate Table.....	7

⚠ WARNING

Before installing this product, read and follow all warning notices and instructions accompanying this filter. Failure to follow safety warnings and instructions can result in severe injury, death, or property damage. Call (800) 831-7133 for additional free copies of these instructions.

Important Notice



Attention Installer.

This manual contains important information about the installation, operation and safe use of this product. This information should be given to the owner/operator of this equipment.

SECTION I. FILTER INSTALLATION

A. GENERAL INFORMATION

1. The filter should be mounted on a level concrete slab. Position the filter so that the instructions, warnings and pressure gauge are visible to the operator. Also, position the filter so that the piping connections, control valve and drain port are convenient and accessible for servicing and winterizing.
2. Install electrical controls (e.g., on/off switches, timers control systems, etc.) at least five (5) feet from the filter. This will allow you enough room to stand clear of the filter during system start up.
3. Provide sufficient clearance around the filter to permit visual verification that the clamp is properly installed, see Figure 1.
4. Provide sufficient space above the filter to remove the filter lid for cleaning and servicing. This distance will vary with the model of filter you are using. See Table 1, for the required vertical clearance.

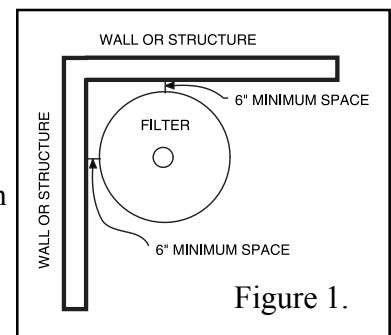

Figure 1.

Pentair Water Pool and Spa, Inc.

1620 Hawkins Ave., Sanford, NC 27330 • (800) 831-7133 • (919) 566-8000
10951 West Los Angeles Ave., Moorpark, CA 93021 • (800) 831-7133 • (805) 553-5000
Visit www.pentairpool.com or www.staritepool.com

 **Pentair** Pool Products®
Because reliability matters most®

⚠ WARNING



Risk of electrical shock or electrocution. Position the filter and High Flow™ manual air relief valve to safely direct water drainage and purged air or water. Water discharged from an improperly positioned filter or valve can create an electrical hazard that can cause severe personal injury as well as damage property.

5. When installing the High Flow™ manual air relief valve use the O-ring only, there is no need for thread sealing compounds. Position the filter to safely direct water drainage. Rotate the valve to safely direct purged air or water. Water discharged from an improperly positioned filter or valve can create an electrical hazard as well as damage property.

6. Make all plumbing connections in accordance with local plumbing and building codes. Filter plumbing connections are provided with an O-ring seal. Use only a silicone base lubricant on the O-rings. Do not use pipe joint compound, glue or solvent on the bulkhead connections.

7. The base of this filter is provided with two (2) mounting bosses for the purpose of anchoring the filter to the concrete.

8. The maximum working pressure of this filter is 50 psi. Never subject this filter to pressure in excess of this amount, even when conducting hydrostatic pressure tests. Pressures above 50 psi can cause the lid to be blown off, which can result in severe injury, death or property damage.

When performing hydrostatic pressure tests or when testing for external leaks of the completed filtration and plumbing system, ensure that the Maximum Pressure that the filtration system will be subjected to DOES NOT EXCEED THE MAXIMUM WORKING PRESSURE OF ANY OF THE COMPONENTS CONTAINED WITHIN THE SYSTEM. In most cases, the maximum pressure will be stated on each component of the system.

If doubt exists as to the pressure to which the system will be subjected, install an ASME approved automatic Pressure Relief or Pressure Regulator in the circulation system for the lowest working pressure of any of the components in the system.

TABLE 1.

Model	P/N	Size	Vertical Clearance Req.
CC50	160314	50 sq. ft.	30 in.
CC75	160315	75 sq. ft.	39 in.
CC100	160316	100 sq. ft.	61 in.
CC150	160317	150 sq. ft.	76 in.
CC200	160318	200 sq. ft.	76 in.

SECTION II. FILTER OPERATION

⚠ WARNING



THIS FILTER OPERATES UNDER HIGH PRESSURE. WHEN ANY PART OF THE CIRCULATING SYSTEM (e.g., LOCK RING, PUMP, FILTER, VALVES, ETC.) IS SERVICED, AIR CAN ENTER THE SYSTEM AND BECOME PRESSURIZED. PRESSURIZED AIR CAN CAUSE THE LID TO BLOW OFF WHICH CAN RESULT IN SEVERE INJURY, DEATH, OR PROPERTY DAMAGE. TO AVOID THIS POTENTIAL HAZARD, FOLLOW THESE INSTRUCTIONS.

1. BEFORE REPOSITIONING VALVES AND BEFORE BEGINNING THE ASSEMBLY, DISASSEMBLY, OR ADJUSTMENT OF THE LOCK RING OR ANY OTHER SERVICE OF THE CIRCULATING SYSTEM: (A) TURN THE PUMP OFF AND SHUT OFF ANY AUTOMATIC CONTROLS TO ASSURE THE SYSTEM IS NOT INADVERTENTLY STARTED DURING THE SERVICING; (B) OPEN AIR RELIEF VALVE; AND (C) WAIT UNTIL ALL PRESSURE IS RELIEVED -PRESSURE GAUGE MUST READ ZERO (0).
2. WHENEVER INSTALLING THE FILTER LOCK RING, FOLLOW THE **FILTER LOCK RING INSTALLATION INSTRUCTIONS EXACTLY.**
3. ONCE SERVICE ON THE CIRCULATING SYSTEM IS COMPLETE, FOLLOW **SYSTEM RESTART INSTRUCTIONS EXACTLY.**
4. MAINTAIN CIRCULATION SYSTEM PROPERLY. REPLACE WORN OR DAMAGED PARTS IMMEDIATELY (e.g., lock ring, pressure gauge, relief valve, O-rings, etc.)
5. BE SURE THAT THE FILTER IS PROPERLY MOUNTED AND POSITIONED ACCORDING TO THE INSTRUCTIONS PROVIDED.

A. GENERAL INFORMATION

1. This filter operates under pressure. When the lock ring is installed properly and operated without air in the water system, this filter will operate in a safe manner.
2. The maximum working pressure of this filter is 50 psi. Never subject this filter to pressure in excess of this amount - even when conducting hydrostatic pressure tests. Pressures above 50 psi can cause the lid to be blown off, which can result in severe injury, death or property damage.

When performing hydrostatic pressure tests or when testing for external leaks of the completed filtration and plumbing system, ensure that the Maximum Pressure that the filtration system will be subjected to DOES NOT EXCEED THE MAXIMUM WORKING PRESSURE OF ANY OF THE COMPONENTS CONTAINED WITHIN THE SYSTEM. In most cases, the maximum pressure will be stated on each component of the system.

If doubt exists as to the pressure to which the system will be subjected, install an ASME approved automatic Pressure Relief or Pressure Regulator in the circulation system for the lowest working pressure of any of the components in the system.

3. The pressure gauge is the primary indicator of how the filter is operating. Maintain your pressure gauge in good working order.

⚠ WARNING



Your filter is a piece of machinery, do not tamper with it, attempt to disassemble it or otherwise adjust it unless you fully understand it's operation. Serious injury or death can occur if the equipment is improperly handled. Consult a pool service professional for maintenance and service assistance.

4. Clean your filter when pressure reads between 8-10 psi higher than the original starting pressure. Your filter pressure reading will increase as it removes dirt from your pool. However, this buildup of pressure will vary due to different bathing loads, temperature, weather conditions, etc.
 - a. MY ORIGINAL STARTING PRESSURE IS _____ psi (pounds per square inch).
I SHOULD CLEAN THE FILTER CARTRIDGES AT _____ psi.

NOTE

When the cartridge element filter is used on new pools and after cleaning the elements, introduce into the system .5 pounds of diatomaceous earth per every 100 square feet of filter area, (a one-pound coffee can equals .5 pounds of diatomaceous earth). Mix the diatomite with water and pour it into the skimmer after the pump is primed and the system is operating. This will enhance the filtration of your water.

B. LOCK RING INSTALLATION INSTRUCTIONS

These instructions **MUST BE FOLLOWED EXACTLY** to prevent the lid from blowing off during system restart or later operation.

1. Perform the following steps before working on any part of the circulating system (e.g., lock ring, pump, filter, valves, etc.).
 - a. Turn the pump off and shut off any automatic controls to ensure that the system is not inadvertently started during servicing.
 - b. Open the High Flow™ manual air relief valve.
 - c. Wait until all pressure is relieved. **Never attempt to assemble, disassemble or adjust the filter lock ring while there is any pressure in the filter.**

⚠ WARNING



THIS FILTER OPERATES UNDER HIGH PRESSURE. WHEN ANY PART OF THE CIRCULATING SYSTEM (e.g., LOCK RING, PUMP, FILTER, VALVES, ETC.) IS SERVICED, AIR CAN ENTER THE SYSTEM AND BECOME PRESSURIZED. PRESSURIZED AIR CAN CAUSE THE LID TO BE BLOWN OFF WHICH CAN RESULT IN SEVERE INJURY, DEATH, OR PROPERTY DAMAGE. TO AVOID THIS POTENTIAL HAZARD, FOLLOW THESE INSTRUCTIONS.

2. Be certain the O-ring is in position in the lower tank half. Place the filter lid over the lower tank half, making sure it is fully and firmly seated on the tank half, see Figure 2.
3. Place lock ring over the tank lid, and centering the lock ring on the threads of the tank body. Turn the lock ring clockwise until the safety latches click and the lock ring hits the stops on the body. **DO NOT ATTEMPT TO OVER-TIGHTEN THE LOCK RING AFTER LOCK RING HAS HIT THE STOPS ON THE BODY.**
4. Follow the System Restart Instructions in Section C.

C. SYSTEM RESTART INSTRUCTIONS

⚠ WARNING



THIS FILTER OPERATES UNDER HIGH PRESSURE. WHEN ANY PART OF THE CIRCULATING SYSTEM (e.g., LOCK RING, PUMP, FILTER, VALVES, ETC.) IS SERVICED, AIR CAN ENTER THE SYSTEM AND BECOME PRESSURIZED. PRESSURIZED AIR CAN CAUSE THE LID TO BE BLOWN OFF WHICH CAN RESULT IN SEVERE INJURY, DEATH, OR PROPERTY DAMAGE. TO AVOID THIS POTENTIAL HAZARD, FOLLOW THESE INSTRUCTIONS.

1. **Open the High Flow™ manual air relief valve until it snaps into the full open position (this only requires a quarter turn counterclockwise).** Opening this valve rapidly releases air trapped in the filter.
2. Stand clear of the filter tank, then start the pump.
3. Close the High Flow™ manual air relief valve after a steady stream of water appears.
4. The system is not working properly if either of the following conditions occur.
 - a. A solid stream of water does not appear within 30 seconds, after the pump's inlet basket fills with water.
 - b. The pressure gauge indicates pressure before water outflow appears.

If either condition exists, **shut off the pump immediately**, open valves in the water return line to relieve pressure, and clean the air relief valve, see Section F. Cleaning the High Flow™ manual air relief valve. If the problem persists, call (800) 831-7133 for assistance.

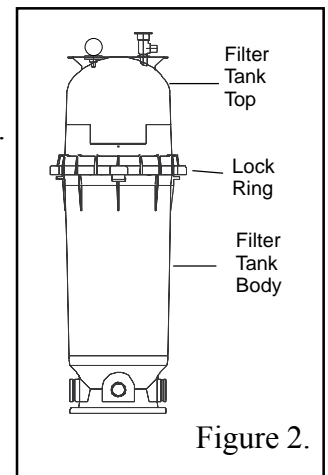

D. CLEANING THE FILTER

⚠ WARNING

The following information should be read carefully since it outlines the proper manner of care and operation for your filter system. As a result of following these instructions and taking the necessary preventative care, you can expect maximum efficiency and life from your filter system.

⚠ CAUTION



Please heed all manufacturers' posted instructions, warnings and cautions when using Baquacil® or Baqua® Clean.

1. Turn the pump off, shut off any automatic controls to ensure that the system is not inadvertently started during servicing.

2. Open the filter High Flow™ manual air relief valve, (and the waste drain valve, or cap, if your system has one).

NOTE

Special care must be taken when cleaning cartridge element used in a swimming pool or spa using Baquacil® as a sanitizer. Because of the way Baquacil® works, the cartridge element must be cleaned more thoroughly and more frequently than in a chlorine system. If extreme care is not taken to completely remove all residue from the cartridge element, a buildup will occur. This buildup will significantly shorten the life of the cartridge element.

Baquacil® is a mild coagulant which combines bacterial cells as well as other small particles contributed by the environment, bathers, etc. into particles large enough to be trapped by the filter. In comparison with all other trapped contaminants in a typical pool or spa the amount of bacterial cells that are deposited on the filter is minimal. The resulting deposit is a gray sticky film which can only be removed with Baqua® Clean. If TSP or any TSP type cleaner is used prior to stripping the film, the cleaner and the gray film will combine to form a gum-like substance. Once this occurs, the substance cannot be removed from the media and the cartridge element must be replaced.

3. Remove hair and lint strainer pot lid and clean basket. Replace basket and secure lid.
4. Disconnect air relief drain hose if installed.
5. Remove locking ring by depressing safety latches on both sides of ring and rotate counterclockwise, then remove tank lid.
6. Remove the element assembly by placing hands in lifting handles and pulling straight up on the element assembly.
7. Remove the cartridge element from the center support tube.
8. Using a garden hose with a nozzle, direct water spray at the cartridge element to dislodge and wash away accumulated foreign matter. Water may be sprayed at the outside as well as the inside of the cartridge element for thorough cleaning.
9. Turn the cartridge element over several times during the washing operation to clean the media thoroughly.
10. Clean and remove debris from inside the filter tank and from the O-ring and O-ring groove on the tank body.
11. Replace clean cartridge element on support tube and install assembly into the filter tank body, aligning the arrow on the support tube with the inlet port of the filter, making sure it is fully seated. Make sure the internal air relief screen is attached to the top of the element support tube.
12. Replace the tank lid onto the tank body making sure it is fully and firmly seated on the tank body.
13. Place lock ring over tank lid, and centering the lock ring on the threads of the tank body, turn the lock ring clockwise until the safety latches click and the lock ring hits the stops on the body. **DO NOT ATTEMPT TO OVER-TIGHTEN THE LOCK RING AFTER LOCK RING HAS HIT THE STOPS ON THE BODY.**

NOTE

Any time the filter tank is opened, and/or element assembly is removed, be sure to generously coat the O-ring with silicone lubricant before reassembling the unit. **DO NOT USE PETROLEUM BASED LUBRICANTS BECAUSE THEY HAVE A DETERIORATING EFFECT ON RUBBER.**

14. Replace drain cap and reinstall High Flow™ manual air relief valve drain hose if used.

E. REPLACING CARTRIDGE ELEMENT

Cartridge element life will vary with pool conditions such as bather load, wind, dust, etc. You can expect an average media life of three (3) years under normal conditions.

1. To replace cartridge element follow steps in section D, Cleaning the Filter.

F. CLEANING THE HIGH FLOW™ MANUAL AIR RELIEF VALVE

1. Turn the pump off and shut off any automatic controls to ensure that the system is not inadvertently started during servicing.
2. **OPEN THE HIGH FLOW™ MANUAL AIR RELIEF VALVE UNTIL IT SNAPS INTO THE FULL OPEN POSITION, THEN WAIT UNTIL ALL PRESSURE IS RELIEVED.**
3. With the relief valve attached to the filter tank, pull out the locking tabs and remove the valve stem and cover assembly with a counterclockwise and lifting motion, see Figure 3.
4. Clean debris from the valve stem and body. Verify that the filter tank's air passage is open by inserting a 5/16 in. drill bit through the valve body. Verify that the O-ring are in good condition, properly positioned, and lubricated with a silicone base lubricant.
5. Reinstall the valve stem and cover assembly with a downward and clockwise motion until it snaps into position.

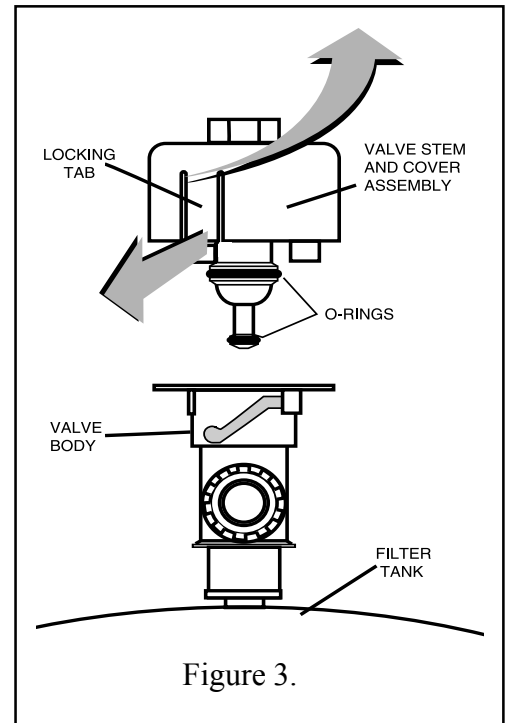

Figure 3.

SECTION III. TROUBLESHOOTING

- A. Air entering your filter is dangerous and can cause the lid to blow off. Correct any conditions in your filtration system that allow air to enter the system.
 1. Some common ways to identify air entering the system:
 - a. Low water level in pool or spa - skimmer is starving for water with pump running. Add water to pool or spa.
 - b. Air bubbles or low water level in pump hair and lint pot are caused by; low water level, clogged skimmer basket, split suction cleaner hose, leak in pump hair and lint pot lid, or leak in pump suction line.
 - c. Air bubbles coming out of water return lines into pool or spa with pump running, see items 1.a and 1.b of this section.
 - d. Air is discharged from the air relief valve on top of the filter when the valve is opened with the pump running, see items 1.a and 1.b of this section, above.
- B. Until the water initially put into the pool has been completely filtered, short filter cycles in between cleanings are normal. In most cases pool owners are dismayed by the undesirable color and appearance of water in a newly filled pool. Plaster dust can be responsible for short filter cycles, requiring frequent cleaning.
- C. If pressure drops on gauge, check skimmer basket and pump basket first for debris. If the baskets are clean, shut off power to pump and turn off any automatic controls. Then turn motor shaft with your fingers. If it turns freely then the pump must be disassembled and the impeller checked to see if it is clogged. If it is not frozen or clogged then there is an obstruction in the line between the pool and the pump.
- D. The pressure gauge is an important part of the filter system. It is your primary indicator of how the system is operating. Maintain your pressure gauge in good working order. Check the operation of your pressure gauge in the following manner:
 1. The pressure gauge should go to zero (0) when the system is turned off and pressure is relieved.
 2. The pressure gauge should indicate pressure when the system is operating.
 3. The pressure gauge should be readable and not damaged in any way.
 4. Replace the pressure gauge if it is not meeting the requirements of items D.1 through D.2 of this section, above.

SECTION IV. TECHNICAL DATA

A. Filter Pressure Loss Chart

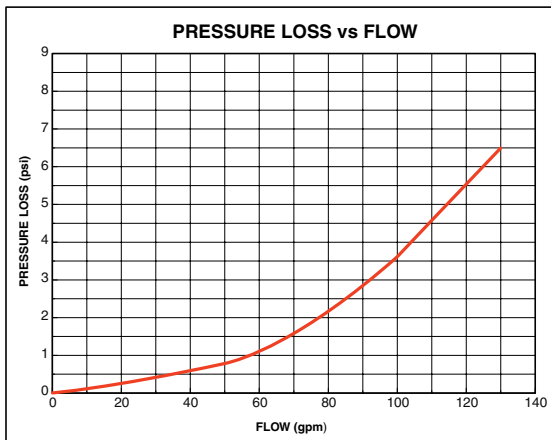

B. Flow Rate Table

Product #	sq. ft.	Residential Maximum Cartridge Flow Rates				Commercial Maximum Cartridge Flow Rates			
		GPM	GPH	6 hour	8 hour	GPM	GPH	6 hour	8 hour
160314	50	50	3,000	18,000	24,000	19	1,140	6,840	9,120
160315	75	75	4,500	27,000	36,000	28	1,680	10,080	13,440
160316	100	100	6,000	36,000	48,000	38	2,280	13,680	18,240
160317	150	150	9,000	54,000	72,000	56	3,360	20,160	26,880
160318	200	150	9,000	54,000	72,000	75	4,500	27,000	36,000

- (1) One GPM per sq. ft. shown, recommended flow rate for residential is .5 GPM per sq. ft.
 (2) Commercial flow rate is a maximum of .375 GPM per sq. ft. of filter area.

NOTE: Actual system flow will depend on plumbing size and other system components.

C. Replacement Parts

Item	Part Number	Description
1	98209800	High Flow™ manual air relief valve
2	190058	Pressure Gauge
3	178553	Lid, 50, 100 sq. ft. filter
4	178561	Lid, 75,150, 200 sq. ft. filter
5	59052900	Locking Ring assy.
6	87300400	Body O-ring
7	59016200	Air Bleed Sock Kit
8	59053500	Center Core, 50 sq. ft. filter
9	59053600	Center Core, 75 sq. ft. filter
10	59053700	Center Core, 100 sq. ft. filter
11	59053800	Center Core, 150, 200 sq. ft. filter
12	R173213	Cartridge Element, 50 sq. ft. filter
13	R173214	Cartridge Element, 75 sq. ft. filter
14	R173215	Cartridge Element, 100 sq. ft. filter
15	R173216	Cartridge Element, 150 sq. ft. filter
16	R173217	Cartridge Element, 200 sq. ft. filter
17	178562	Bottom, 50 sq. ft. filter
18	178554	Bottom, 75 sq. ft. filter
19	178563	Bottom, 100 sq. ft. filter
20	178560	Bottom, 150, 200 sq. ft. filter
21	86202000	Drain Cap Assy.
22	51005000	Drain Cap Gasket
23	39104500	Union Nut "C" Clip
24	98212200	Union Nut
25	071426	Union O-ring
26	79304600	Body, Swivel

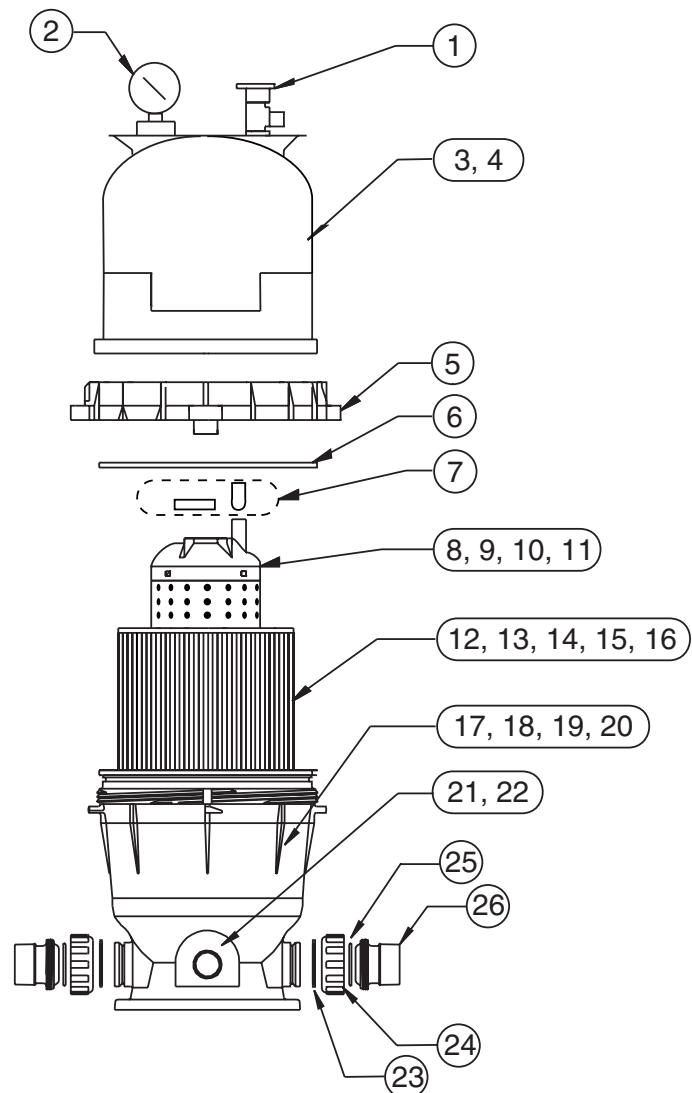

SAVE THESE INSTRUCTIONS

© 2009 Pentair Water Pool and Spa, Inc. All rights reserved.

1620 Hawkins Ave., Sanford, NC 27330 • (800) 831-7133 • (919) 566-8000
10951 West Los Angeles Ave., Moorpark, CA 93021 • (800) 831-7133 • (805) 553-5000

This document is subject to change without notice.

Trademarks and Disclaimers: Pentair Pool Products®, Because reliability matters most®, Clean & Clear®, and High Flow™, are trademarks and/or registered trademarks of Pentair Water Pool and Spa, Inc. and/or its affiliated companies in the United States and/or other countries. Baquacil® and Baqua® are registered trademarks of Arch UK Biocides Limited. Unless noted, names and brands of others that may be used in this document are not used to indicate an affiliation or endorsement between the proprietors of these names and brands and Pentair Water Pool and Spa, Inc. Those names and brands may be the trademarks or registered trademarks of those parties or others.



CLEAN & CLEAR®

CARTRIDGE FILTER



CRYSTAL CLARITY WITH CARTRIDGE CONVENIENCE

The Clean & Clear filter combines top-end filter performance with low maintenance. This dependable design uses special filter elements to strip tiny particles from your pool water...particles as small as 20 microns. (An average grain of beach sand is 1,000 microns!) Plus, cleaning is a breeze. Open the top, remove the cartridge, hose it off and the Clean & Clear filter is ready to go again.



We've maximized cartridge surface consistency to block and trap the maximum amount of solids. Plus, we use the most durable materials to extend cartridge life. The Clean & Clear filter will keep your pool sparkling day in and day out.

- Cartridge is easy to remove and rinse.
- Clamp ring allows easy access to cartridge and internal parts.
- Single-piece base and tank are constructed of fiberglass-reinforced polypropylene for strength and chemical resistance.
- High-Flow™ Manual Air Relief Valve and continuous internal air relief work together to maintain optimum filtration efficiency at all times.

CLEAN & CLEAR[®]

CARTRIDGE FILTER

Clamp ring for quick access to cartridges

Single-piece fiberglass-reinforced polypropylene tank for strength and corrosion resistance

2" plumbing for maximum flow

Easy access 1½" drain

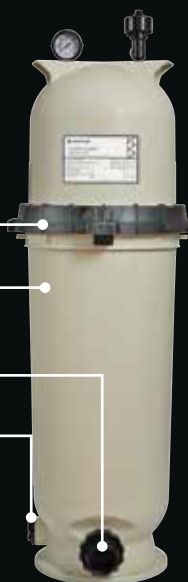

Model Number	Filter Area Sq. Ft.	Vertical Clearance*	Filter Diameter	Flow Rate GPM	Turnover Capacity (Gallons)		
					8 hrs.	10 hrs.	12 hrs.
CC 50	50	30"	15.5"	50	24,000	30,000	36,000
CC 75	75	39"	15.5"	75	36,000	45,000	54,000
CC 100	100	61"	15.5"	100	48,000	60,000	72,000
CC 150	150	76"	15.5"	150	72,000	90,000	108,000
CC 200	200	76"	15.5"	150	72,000	90,000	108,000

* Required clearance to remove filter elements

CAREFREE BY DESIGN

Like all Pentair cartridge filters, the Clean & Clear filter features an easily-cleaned cartridge for the ultimate in carefree pool filtration. The fiberglass-reinforced tank halves are secured with a clamp ring—just loosen the ring and remove the top half for easy cartridge access and rinsing. Filter maintenance doesn't get any easier.

- 1½" drain and washout for quick and convenient maintenance and winterization.
- Lock-ring requires only half of a revolution for a leak-proof seal.
- 2" plumbing for maximum flow.
- Single-piece base and body designed for maximum durability.

AVAILABLE FROM:



1620 HAWKINS AVE, SANFORD, NC 27330 800.831.7133 WWW.PENTAIRPOOL.COM

All Pentair trademarks and logos are owned by Pentair or one of its global affiliates. Clean & Clear[®] and High-Flow[™] are trademarks and/or registered trademarks of Pentair Water Pool and Spa, Inc. and/or its affiliated companies in the United States and/or other countries. Because we are continuously improving our products and services, Pentair reserves the right to change specifications without prior notice. Pentair is an equal opportunity employer.

pumps • filters • heaters • heat pumps • automation • lighting • cleaners • sanitizers • water features • maintenance products

9/14 Part # P1-121 ©2014 Pentair Water Pool and Spa, Inc. All rights reserved.

